

R 1200 C Gearbox Repair Procedures

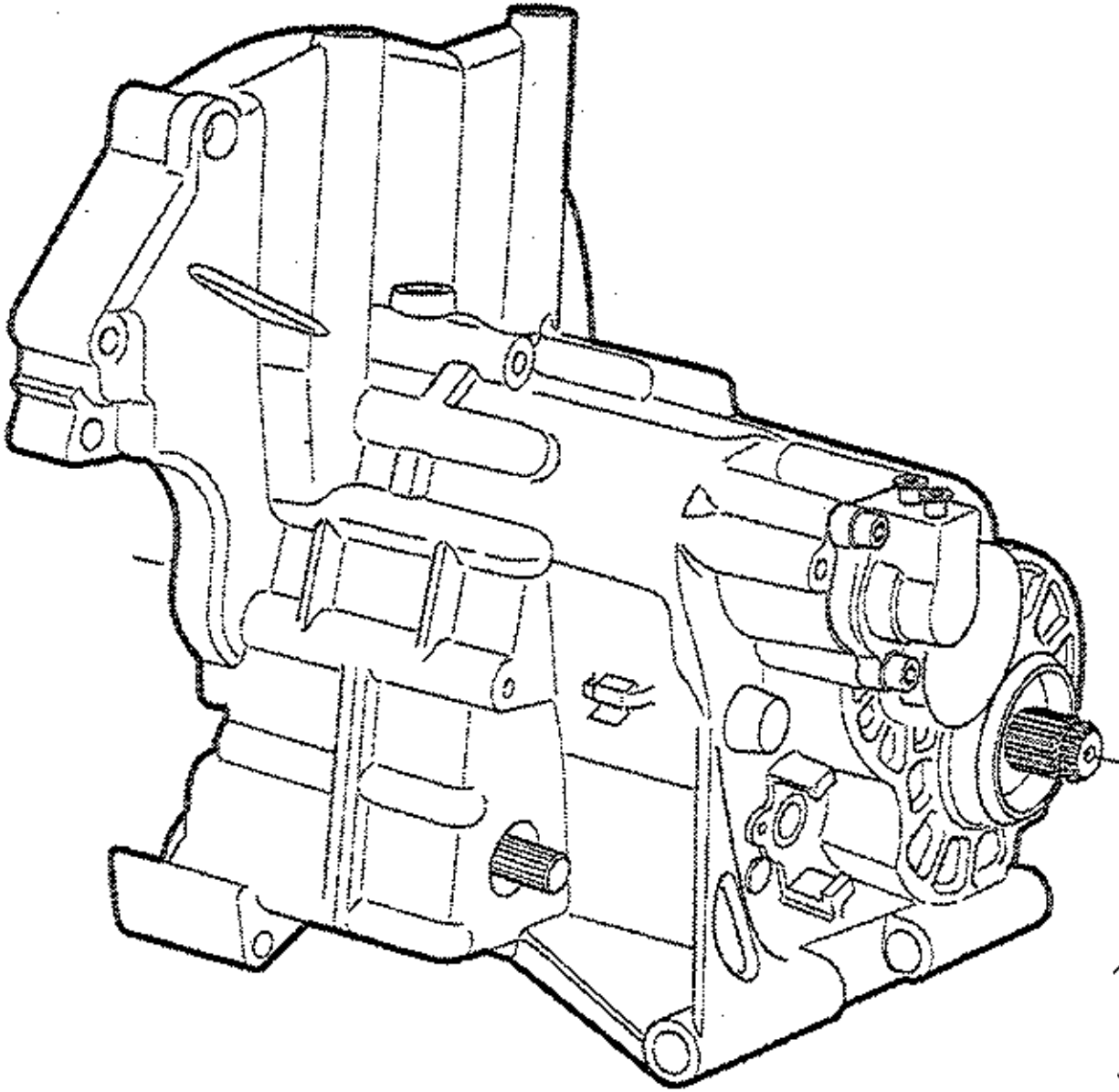

Removing Gearbox

- Place the MC on auxiliary stand
- BMW tool # 90 88 6 00 1 550
- Remove the seat.
- Remove the left & right air duct trim panels.
- Remove the fuel tank.

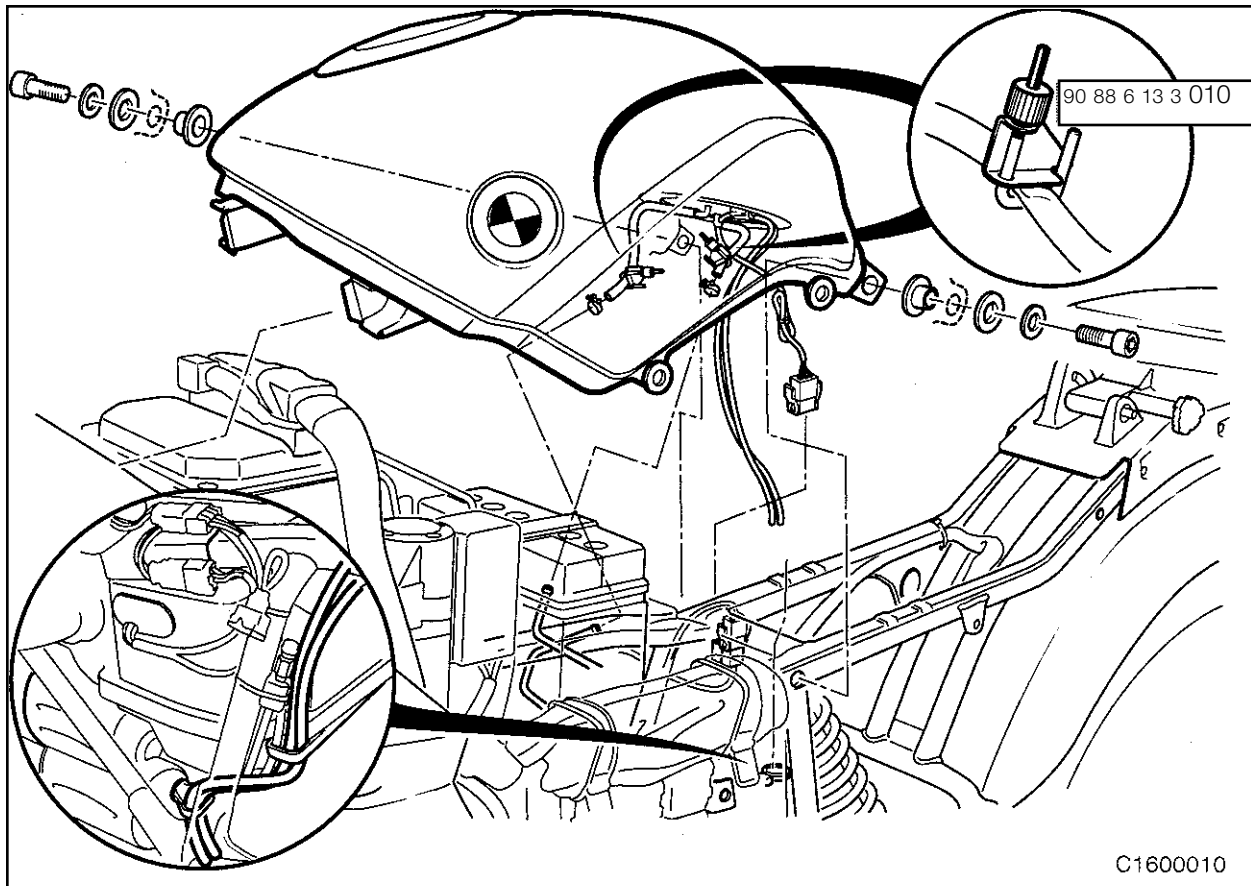
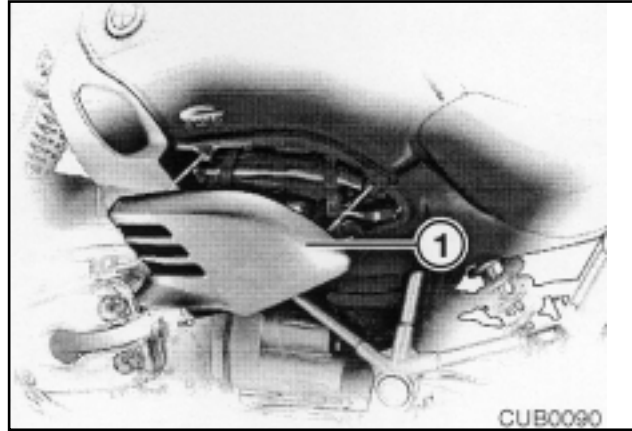

Removing the fuel tank:

Caution: Fuel is highly flammable and also represents a health risk. Use reasonable safety precautions.

- Use special tool 90 88 6 13 3 010 to clamp both fuel lines prior to detaching them.
- Disconnect the vent and drain lines.
- Disconnect the fuel pump connector.
- Take off the fuel tank.

Remove the mufflers

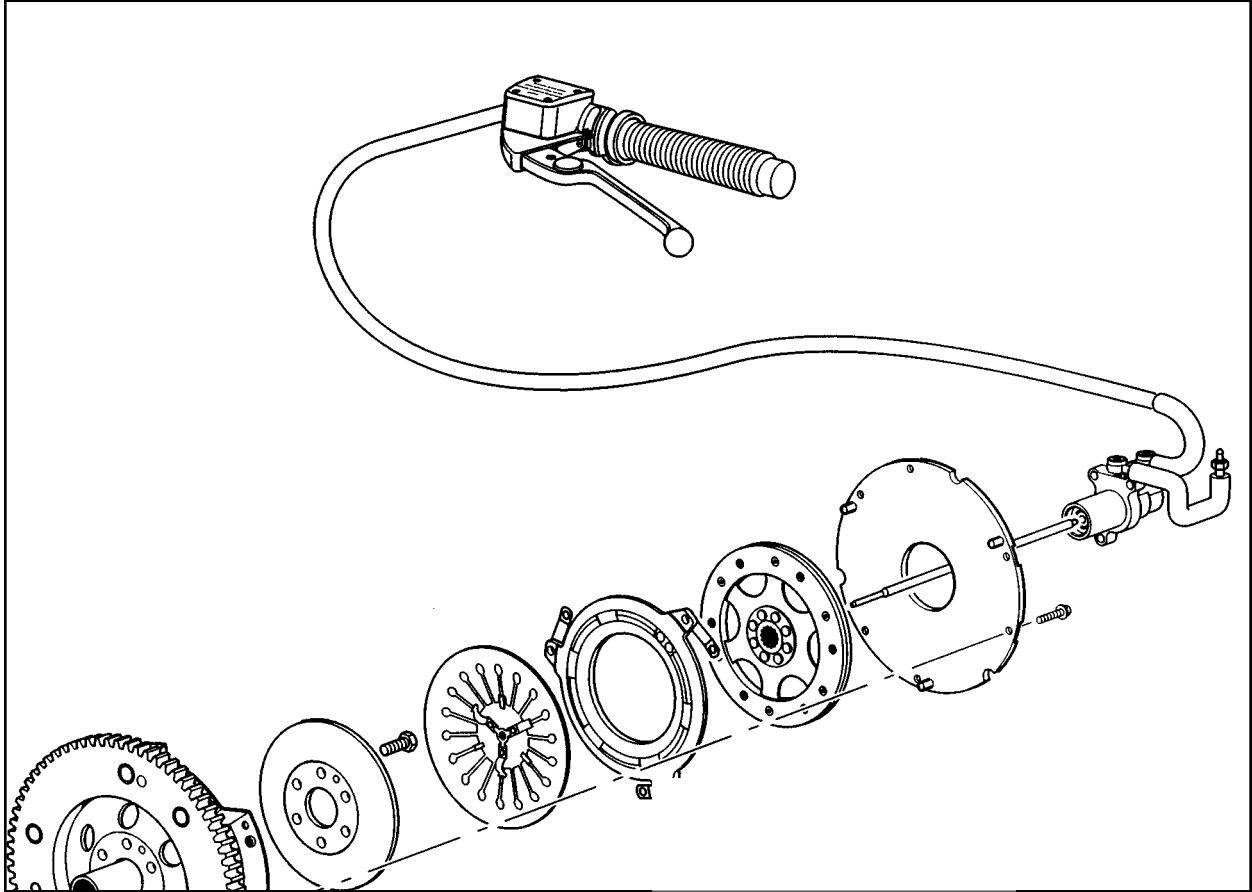

- Loosen clamp bolts.
- Disconnect O2 sensor wire connector.
- Remove two clips.
- Pull mufflers back and down.

Remove rear wheel/Rear drive/swing arm

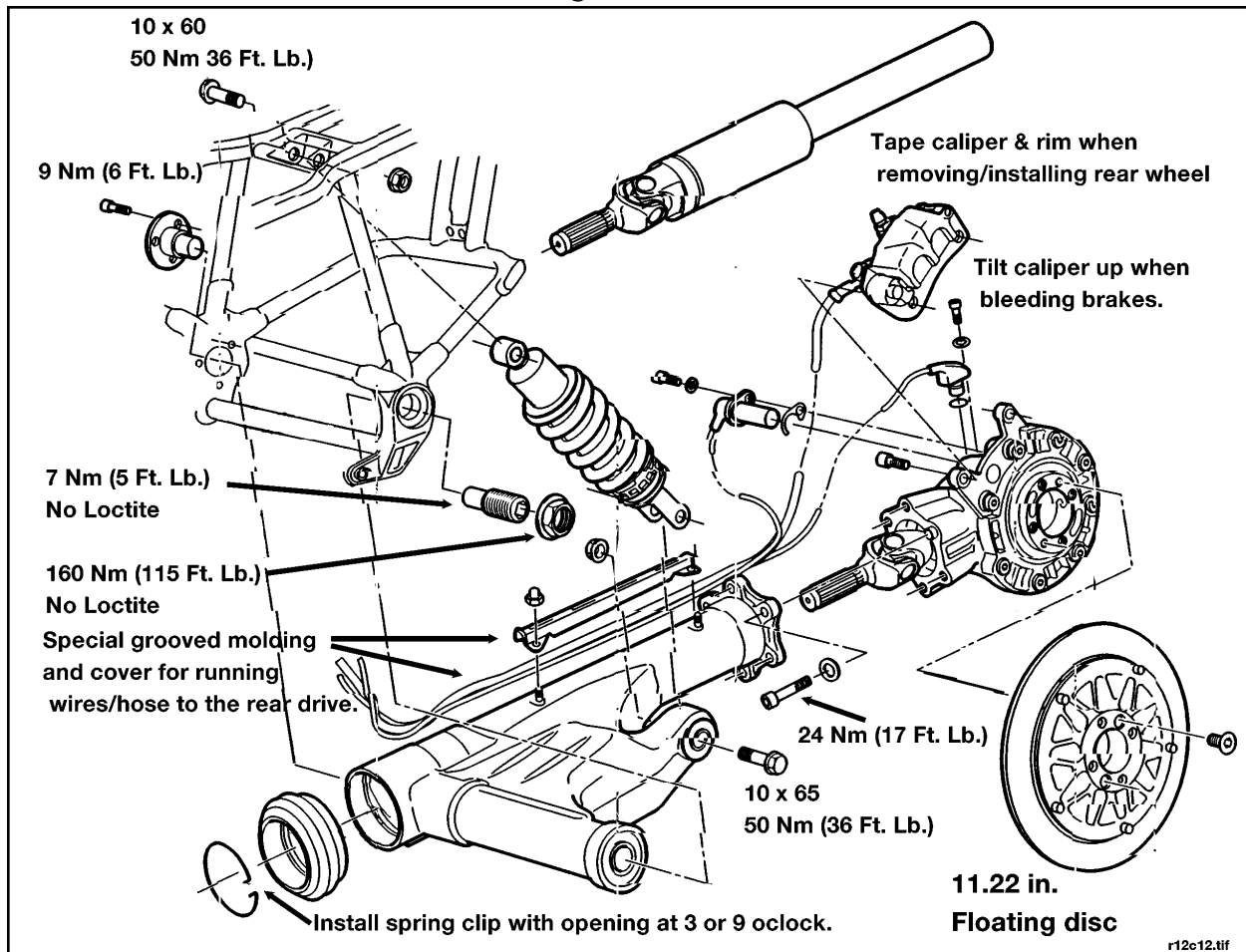

- Remove the speedo pick-up sensor from the rear drive.
- Remove the ABS sensor if applicable.
- Remove the rear brake caliper.
- Remove the rear wheel.
- Place gearbox into 1st gear.
- Remove the rear wheel.
- Remove the rear drive.
- Remove the track holding the brake hose & wires from on top the swing arm.
- Remove the rear shock.
- Remove the swing arm & drive shaft.

Removing rear fender and frame

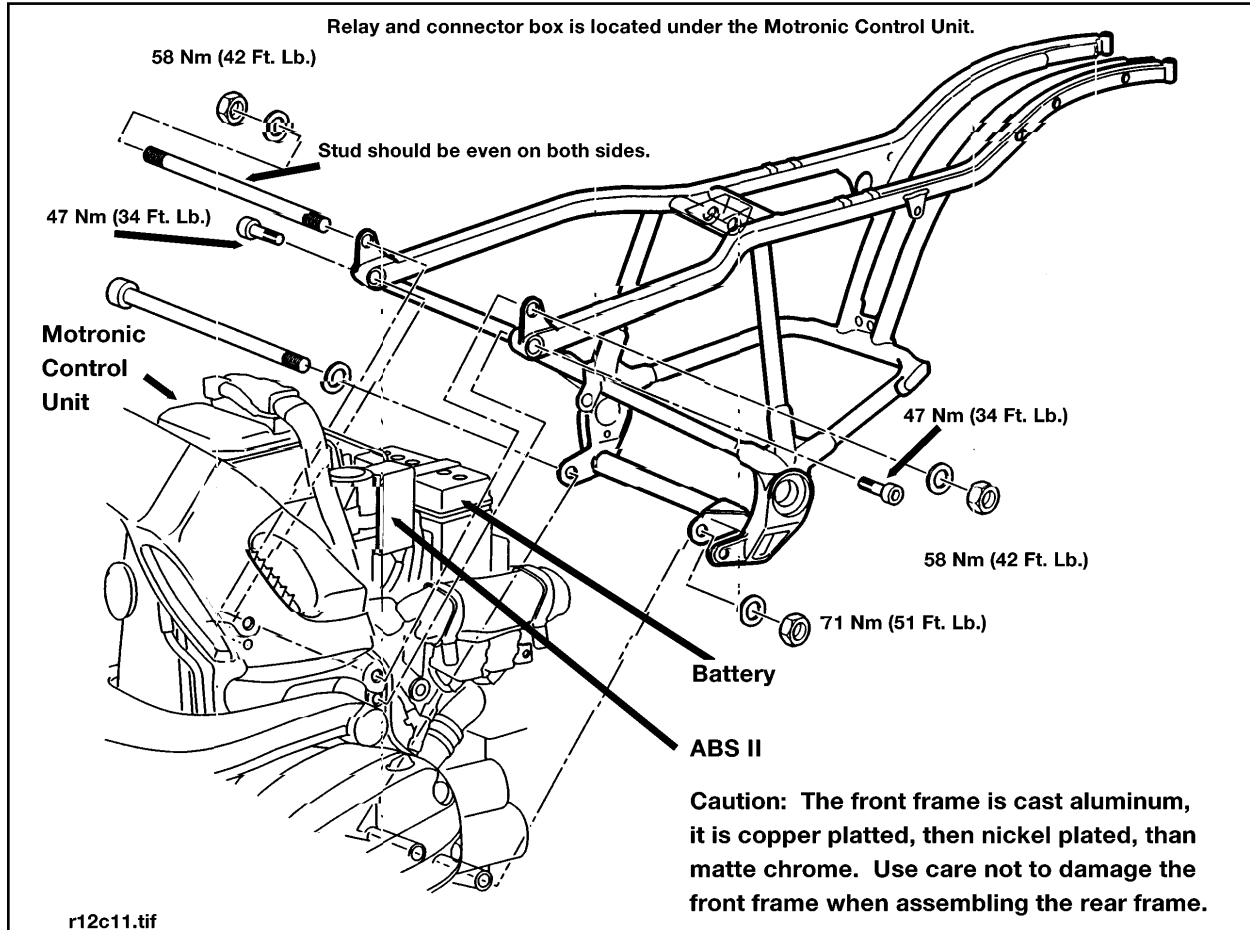

- Remove the foot shift lever.
- Remove the starter cover.
- Remove the starter.
- Disconnect the wire and hose connections for charcoal canister.
- Disconnect the wire connection for rear light and turn signals.
- Remove the rear frame and rear fender.
- Remove the battery.

Caution: Disconnect the negative terminal first, then the positive terminal. When installing reverse the connection order.

- On ABS models use a crate strap to hold ABS unit up.

- Remove the cover from the access for the throttle cable.
- Disconnect the throttle cable and remove it from the air box.

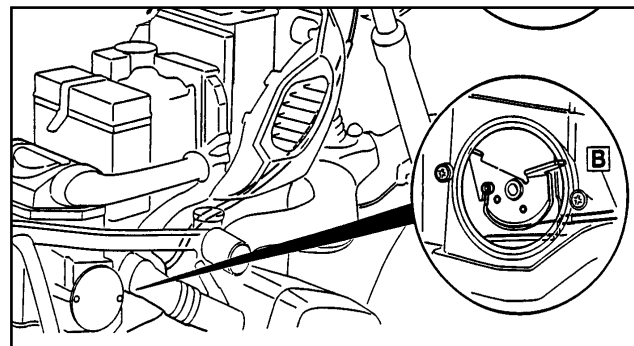

Removing the air box

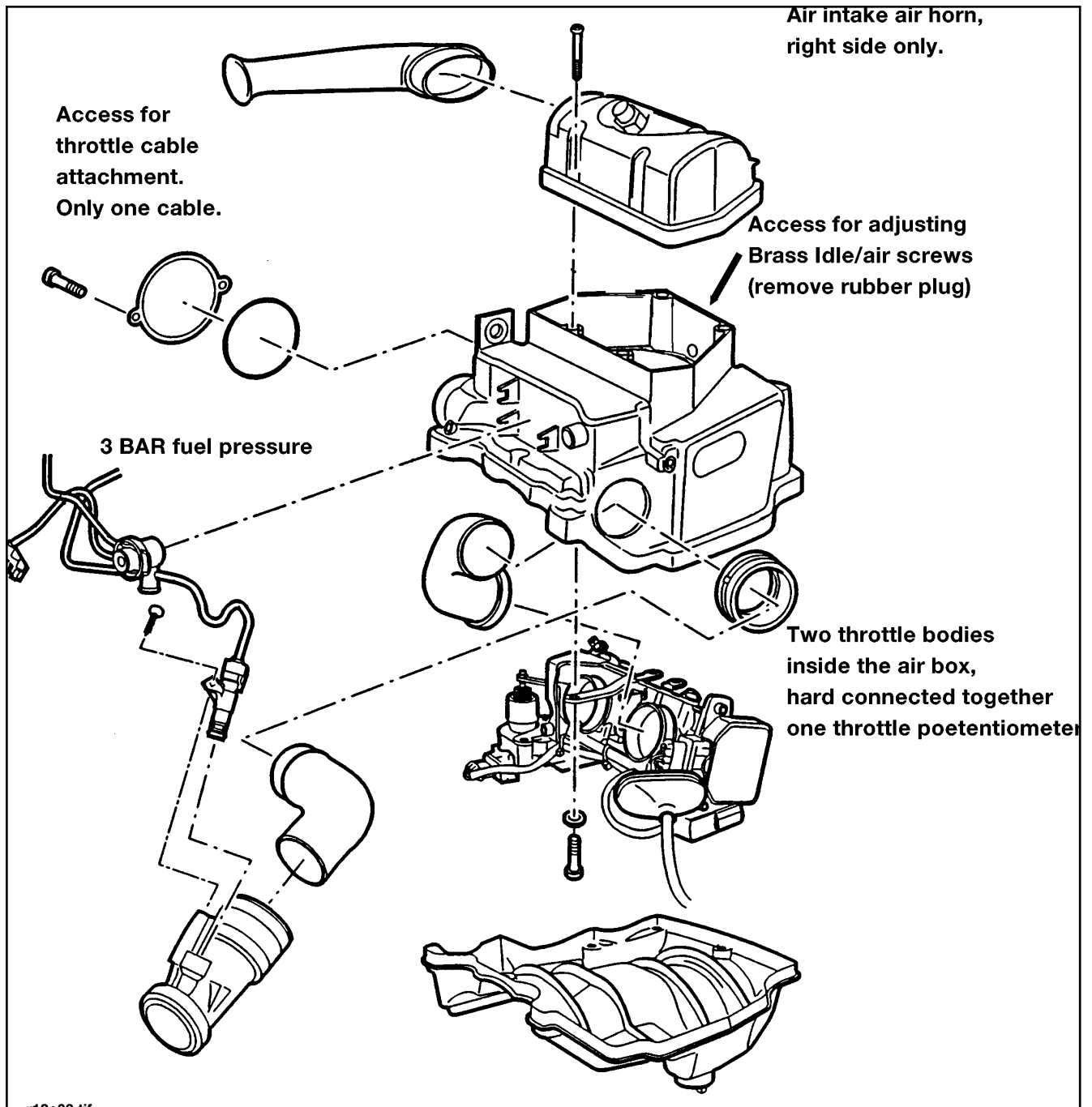

- Disconnect the wire connection for the throttle poentimeter.
- Disconnect the wire connection for idle speed and choke controller.
- Remove fuel injector & the air tube intake elbows.
- Remove the air intake tube.
- Unplug the air temperature sensor.
- Remove the air filter cover and air filter.
- Remove hoses and drain lines.
- Remove the balance of the air box as a unit.

- Disconnect the neutral wire connector.
- Unbolt the clutch slave unit without breaking the connection on the hydraulic line.
- Remove the clutch release rod from the gearbox.
- Drain gearbox oil.
- Loosen the gearbox bolts and remove.
- Remove the gear box

Note: Repair procedures are similar to K 1200 RS.

Dismantling gearbox

- Mark the position of the shift lever to the shift lever shaft with a sharp chisel.
- Remove the shift lever.

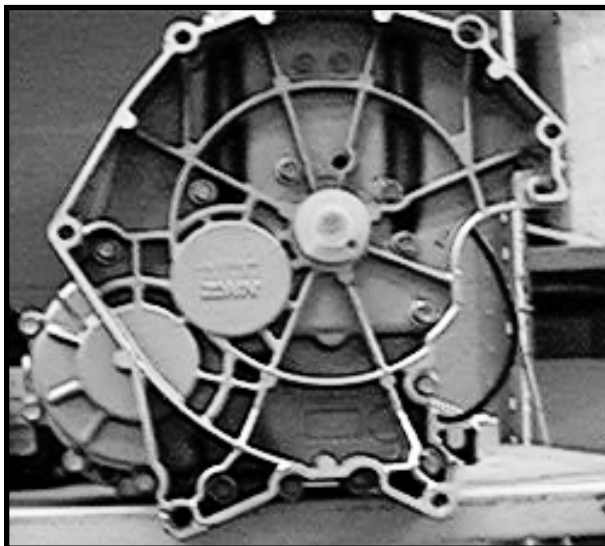
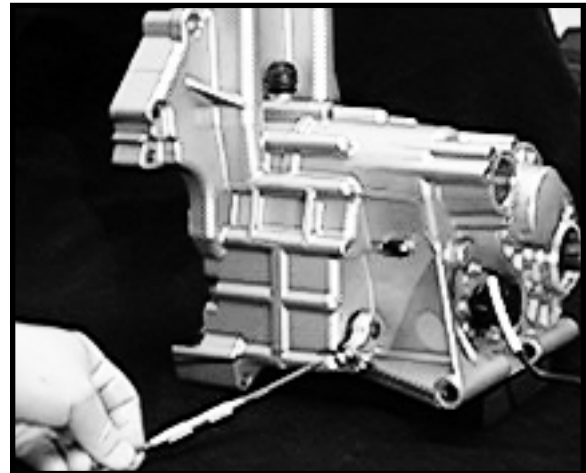

- Remove the fifteen hex bolts from the front gearbox cover.

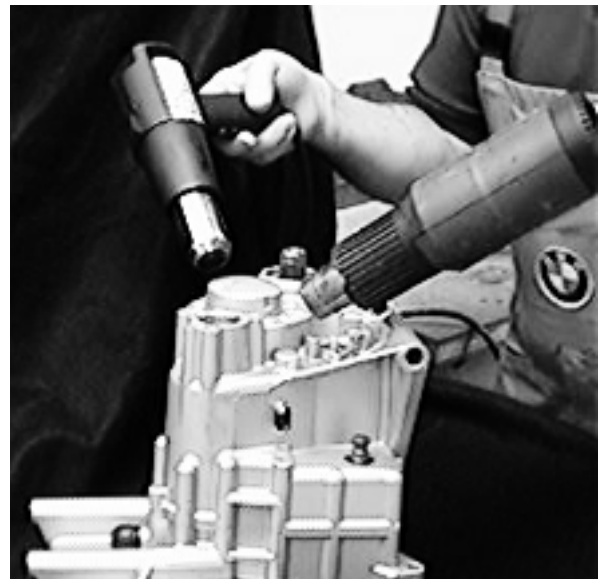

- Place gearbox face down on work bench, heat to 100° C with hot air around bearing area in the housing.
- Heat around the two (arrows above) locating pins.
- Use a flat end pin punch and tap the locating pin into the cover while hot. The housing will raise while tapping on the locating pins,
- Tap the housing with a dead blow hammer and remove housing.

Removing selector drum

Note: The repair procedures for the R 1200 C gearbox and the K 1200 RS are similar, even though the shafts and shift drum arrangement are different. Because all R 1200 line drawings are not available at this time, K 1200 drawings have been used in some illustrations.

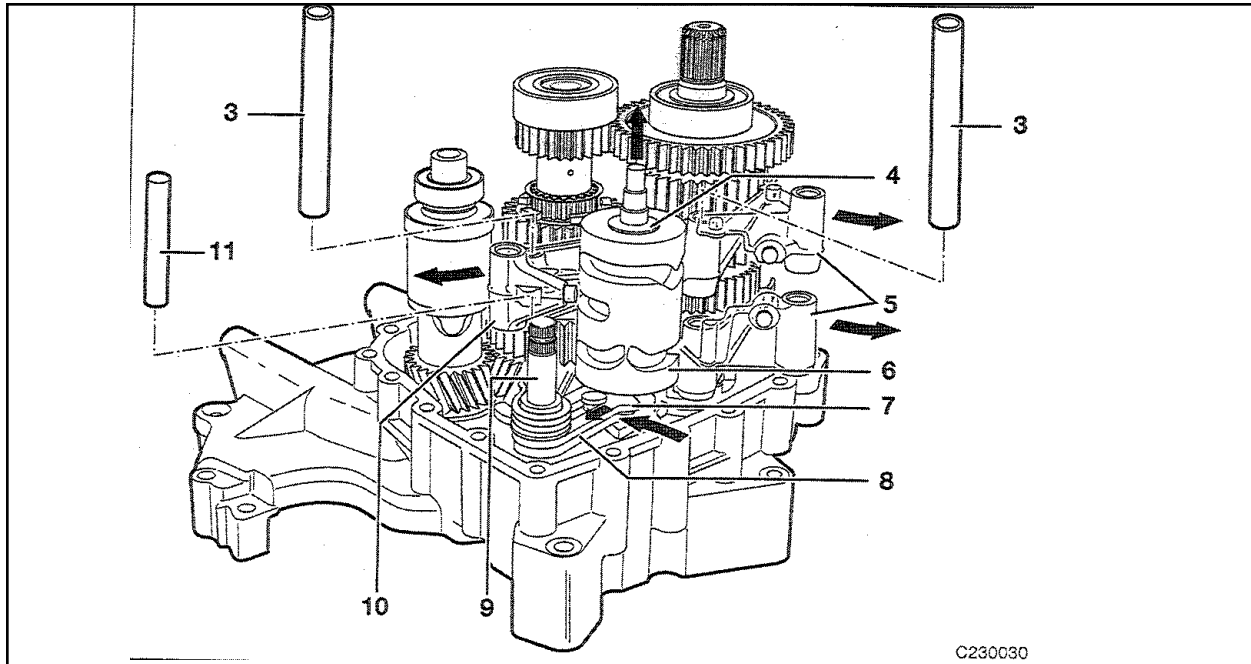

Dismantling/assembling selector

- Pull selector shafts (1) out of selector forks.
- Swing selector forks (3, & 8) out towards the edge of the cover.
- Remove locking pin (9).
- Press guide plate (5) in the opposite direction to the spring loading (arrow).
- Swing locking lever (6) out towards the edge of the cover, hold it there and pull out selector drum (4), turning it slightly at the same time.
- Remove the thrust washer and spacing washer.
- Release the locking lever (6).
- Remove selector shaft (7) with spacing washer.
- Remove selector forks (3).
- Selector fork (8) remains with intermediate shaft (10).

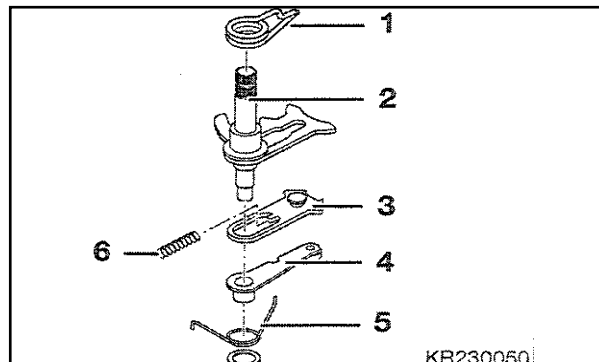

- Remove torsion spring (5) with locking lever (4) from selector shaft (2).
- Remove torsion spring (1).
- Remove coil spring (6) with sliding plate (3).
- Assemble in the opposite order of work.

Removing gearbox shafts

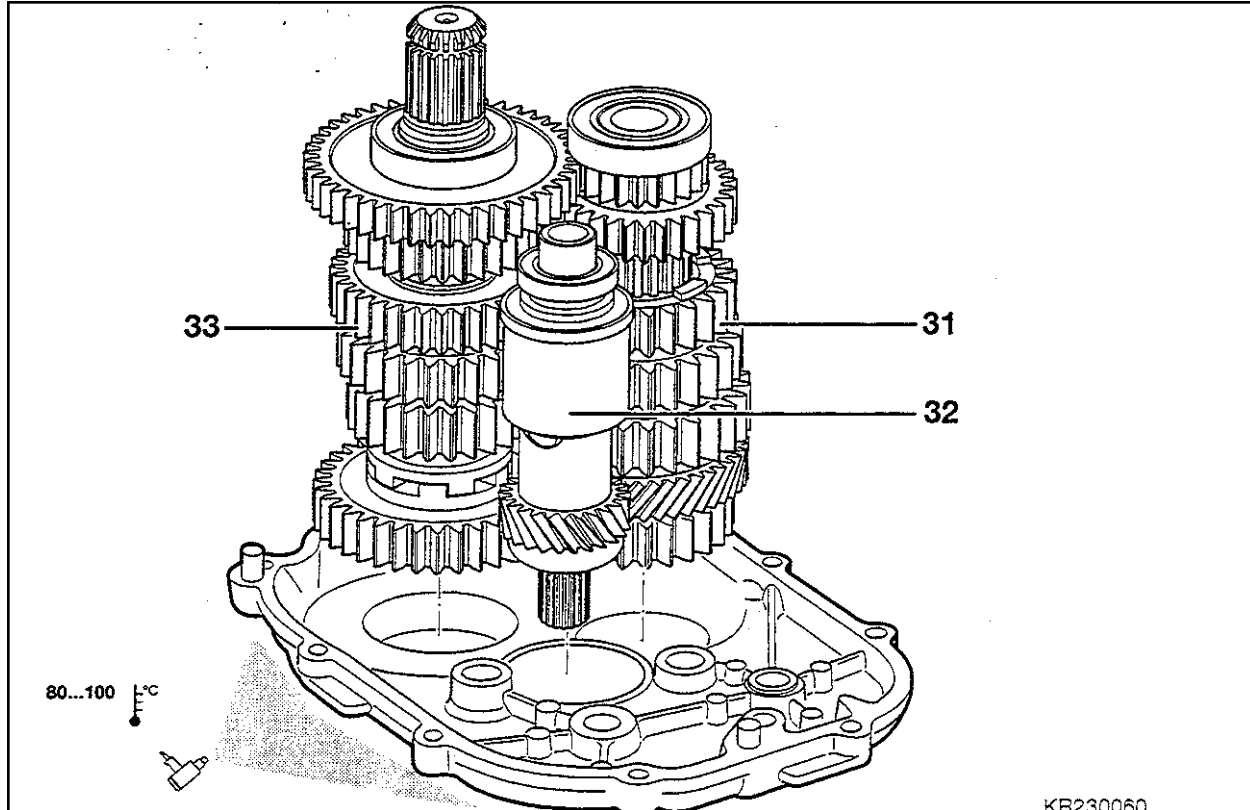

- Heat bearing points in gearbox cover to 80° C ... 100° C.
- Remove input shaft (32), output shaft (33) and intermediate shaft (31) from the cover together.

Renew the deep-groove ball bearings for the intermediate shaft

Caution: Except from the deep-groove ball bearings, the intermediate shaft must always be renewed as a complete unit.

If the deep-groove ball bearings are renewed, the fully compressed length must be adjusted.

- Pull off the deep-groove ball bearings with a universal puller, BMW No. 90 88 6 00 7 500.
- Press the output side deep-groove

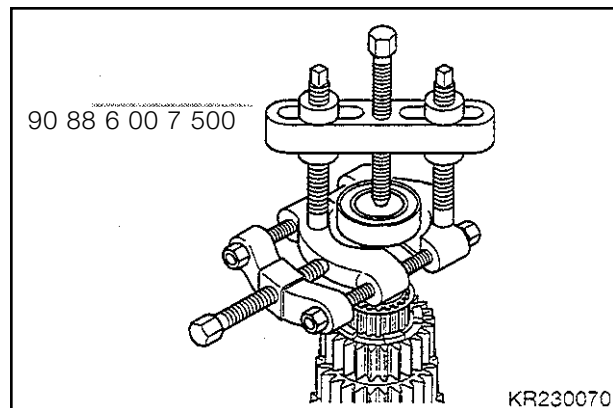

ball bearing on to the intermediate shaft.

- Check/adjust the fully compressed length (Repair Manual 23.19).
- Place the spacing washer of the determined thickness in position and press on the input side deep-groove ball bearing.

Dismantling/assembling input shaft

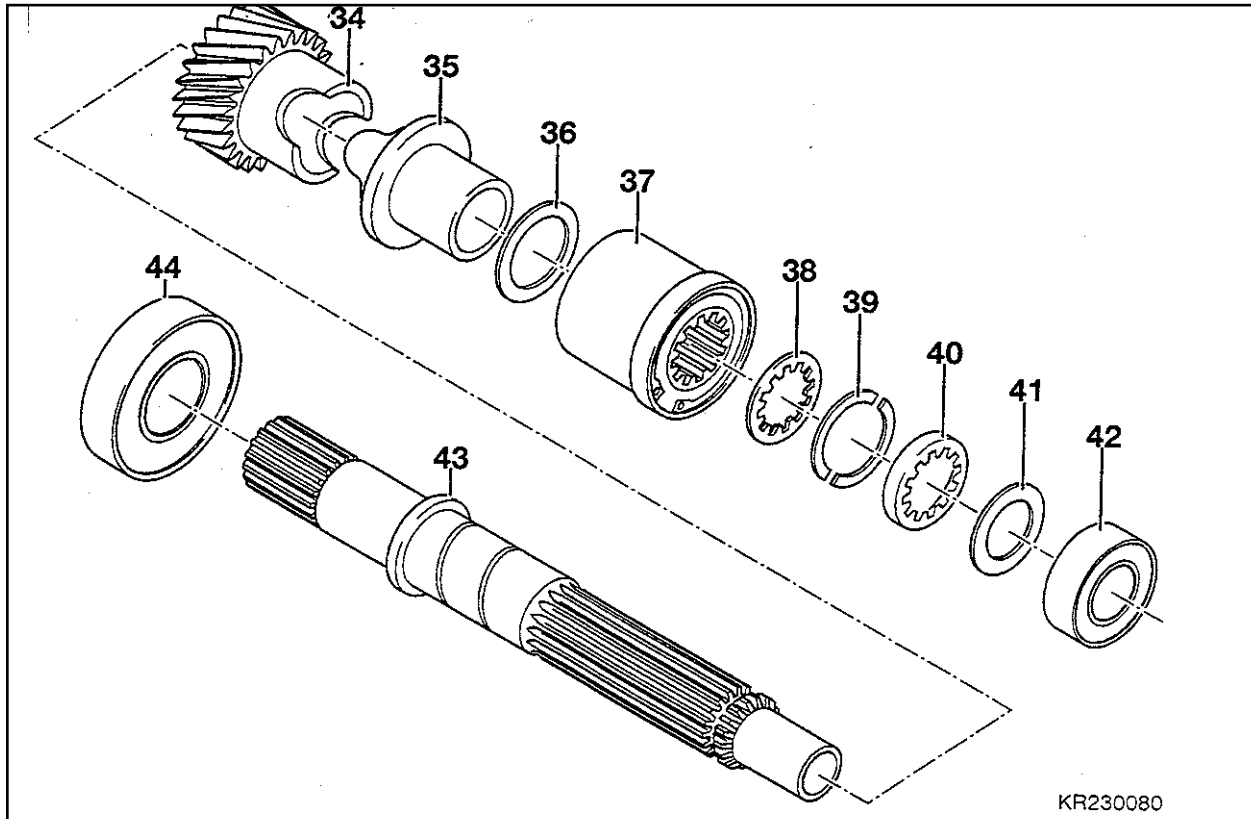

Dismantling input shaft

- Clamp input shaft (43) into the vise,
- Remove retaining sleeve (40), split segment washer (39), support washer (38), spring segment (37), corrugated washer (36), thrust block (35) and constant-speed gear (34).
- Transfer input shaft (43) to a different position. Use universal puller, BMW No. 90 88 6 00 7 500, and pressure head (arrow) to pull off deep-groove ball bearing (44).

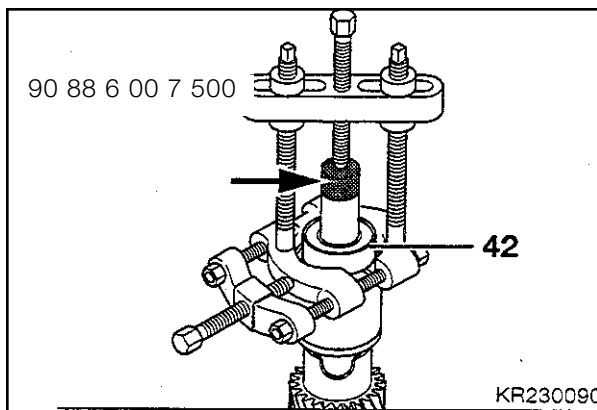

using soft jaws.

- Use universal puller, BMW No. 90 88 6 00 7 500, and pressure head (arrow) to pull off deep-groove ball bearing (42) with spacing washer (41).

Note: Note the thickness of spacing washer (38).

Assembling input shaft

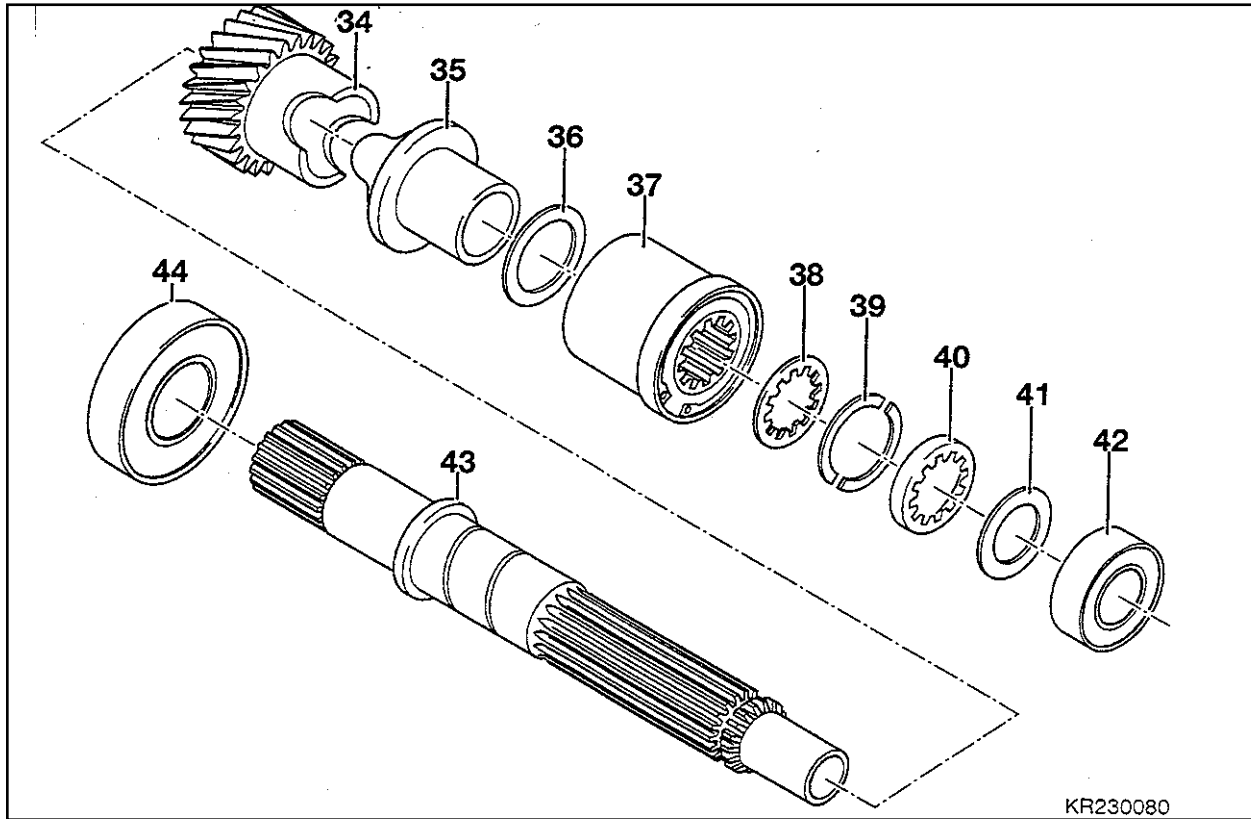

- Oil the bearing surface for constant speed gear (34) lightly on input shaft (43), and install the constant speed gear.
- Oil the splines in thrust block (35) lightly and install it.
- Place corrugated washer (36) on thrust block (35).
- Place spring segment (37) and circlip (arrow) facing upward on corrugated washer (36).
- Install a support washer (38) of the same thickness as the one previously removed.
- Compress spring segment (37) and insert split segment washer (39) into ring groove.
- Install retaining sleeve (40) with the shoulder facing over segment washer (39).
- Check the fully compressed length and adjust if necessary. (Repair Manual 23.20)
- Install spacing washer (41) of the determined thickness, and press on deep-groove ball bearing (42).

Caution: Check end play at the spring segment. If end play is greater than the tolerance limit, the cause may be wear or incorrect assembly.

End play: Spring segment on shaft 0.4 - 0.6 mm (0.016 - 0.024 in)

Dismantling/reassembling output shaft

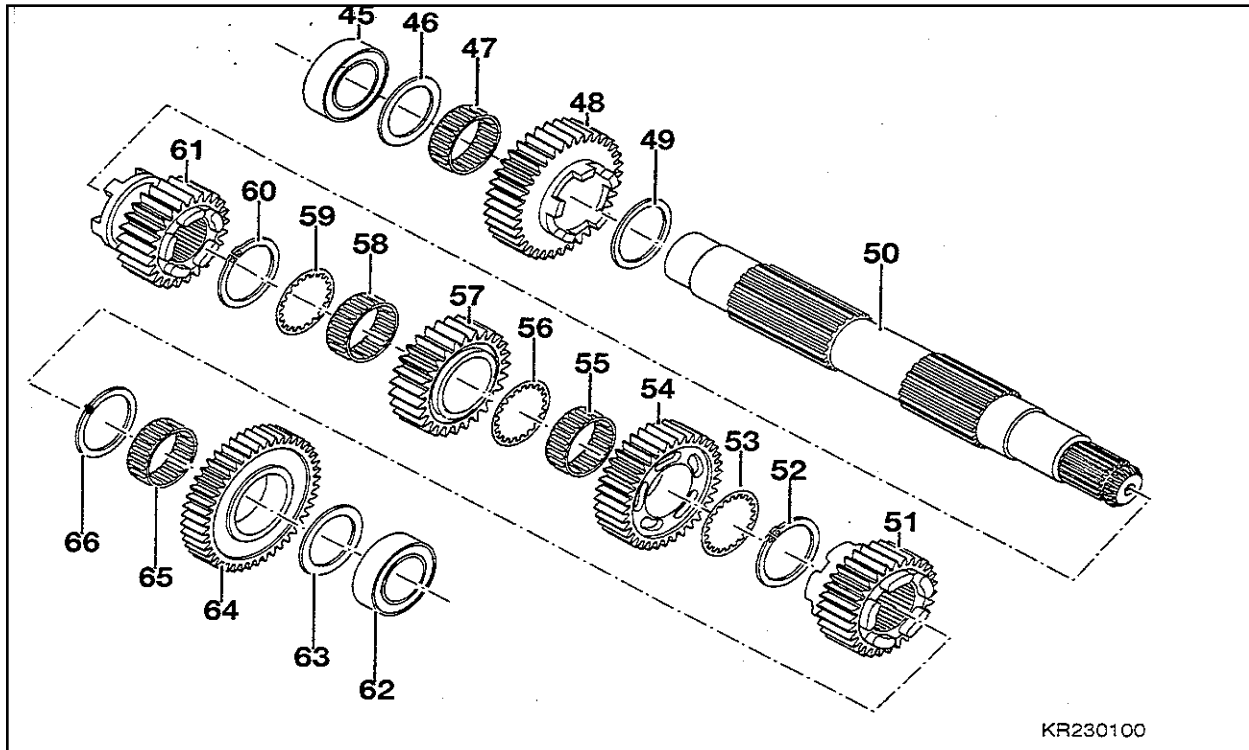

Stripping down output shaft

Caution: To avoid damaging the needle roller bearing at the splines, open it out carefully at the joint line before removing.

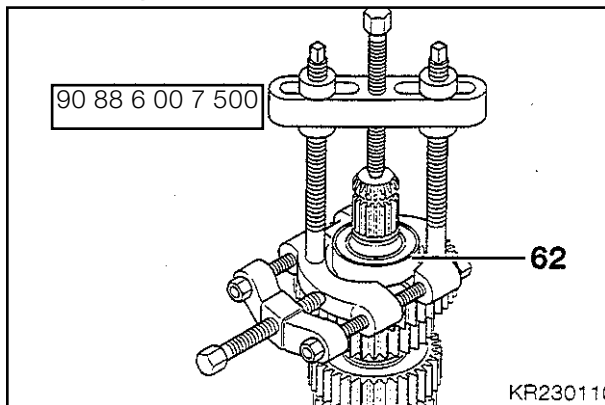

- Use universal puller, BMW No. 00 7 500, to pull off deep-groove ball bearing (62).
- Remove spacing washer (63), 1st gear shift wheel (64), needle roller bearing (65) and spacing washer (66).
- Remove the sliding gearwheel for 5th gear (51).

- Remove circlip (52), support washer (53), shift gearwheel for 3rd gear (54) and needle roller bearing (55).
- Remove support washer (56), shift gearwheel for 4th gear (57), needle roller bearing (58) and support washer (59).
- Remove circlip (60) and sliding gearwheel for fifth gear (61).
- Turn output shaft (50) and clamp into the vise with soft jaws.
- Use universal puller, BMW No. 90 88 6 00 7 500, to pull off deep-groove ball bearing (45).
- Remove shim washer (46), needle roller bearing (47), shift gearwheel for 2nd gear (48) and thrust washer (49).

Assembling output shaft

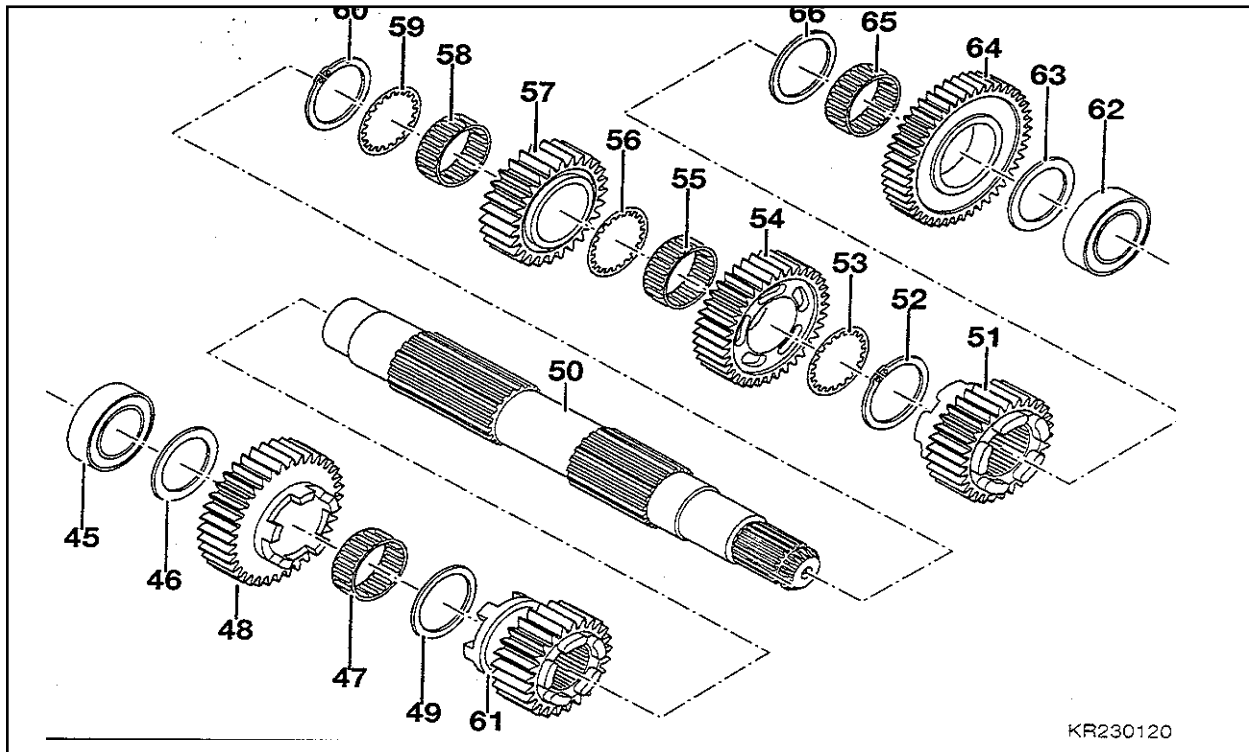

Note: Assembly starts at the shift gear-wheel for 4th gear. Before assembly, oil all running surfaces lightly with gear oil.

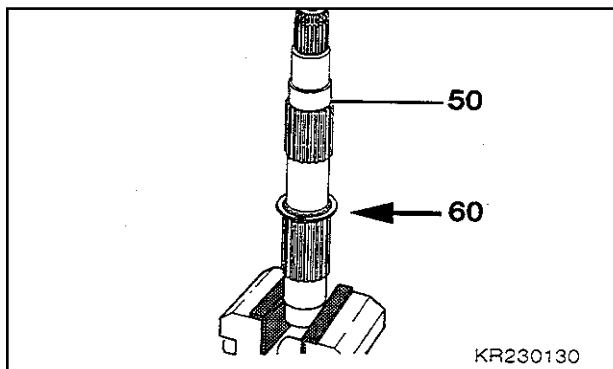

- Clamp the output shaft into the vise with soft jaws and with the splines facing upwards.
- Install circlip (60/arrow).
- Install support washer (59).

Caution: To avoid damaging the needle roller bearing at the splines when installing, open it up carefully at the joint line.

- Install needle roller bearing (58).
 - Install shift wheel for 4th gear (57) with the pockets facing circlip (60).
 - Install support washer (56) and needle roller (55).
 - Install shift wheel for 3rd gear (54) with pockets facing away from the 4th gear shift wheel (57).
 - Install support washer (53) and circlip (52).
 - After installing, measure end play at 3rd and 4th gear shift wheels.
 - Install shift wheel for 5th gear (51) with recess for shift fork facing towards the 3rd gear shift wheel (54).
 - Install support washer (66) and needle roller bearing (65).
 - Install shift wheel for 1st gear (64) with the pockets facing towards the 5th gear shift wheel (51).
 - Install spacing washer (63) and deep-groove ball bearing (62).
- After installing, check end play at 1st gear shift wheel.

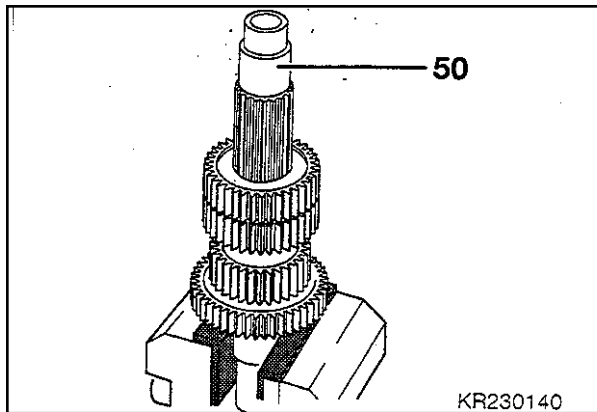

- Transfer output shaft (50) to new position in vise.
- Install shift wheel for 6th gear (61) with the recess for the selector fork facing the 2nd gear shift wheel (48).
- Install support washer (49) and needle roller bearing (47).
- Install the shift wheel for 2nd gear (48) with the dogs facing the 6th gear shift wheel (61).
- Check/adjust fully compressed length. (Repair Manual 23.20)
- Install a spacing washer (46) of the determined thickness and press on deep-groove ball bearing (45).
- Check 2nd gear end play.

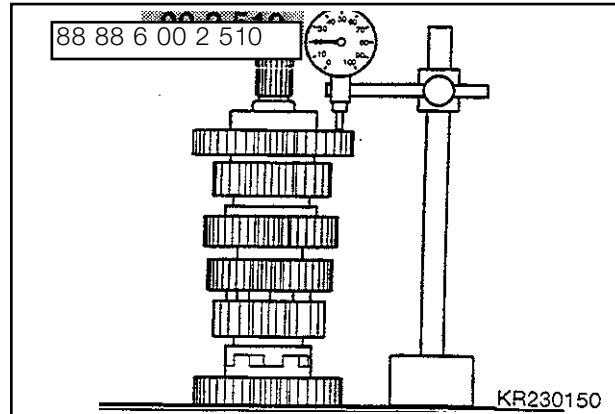

Checking end play

- Set up dial gauge, BMW No. 88 88 6 00 2 510, to dial gauge stand.
- Set as shown above, dial gauge, BMW No. 88 88 6 00 2 510, to the edge of the shift gear which is to be checked, and check end play.

Caution: If end play is beyond the permitted tolerances, this indicates either an assembly error or wear in the needle roller bearings, the support or spacing washer or the shift gear.

- Check for wear and renew the affected parts.

End play values:

1st, 0.1-0.33 mm (0.004 - 0.013 in)
 2nd, 0.1-0.33 mm (0.004-.0.013 in)
 3rd/4th gear
 0.1-0.67 mm (0.004 - 0.026 in)

Renewing the shaft sealing rings in the gearbox housing and gearbox cover

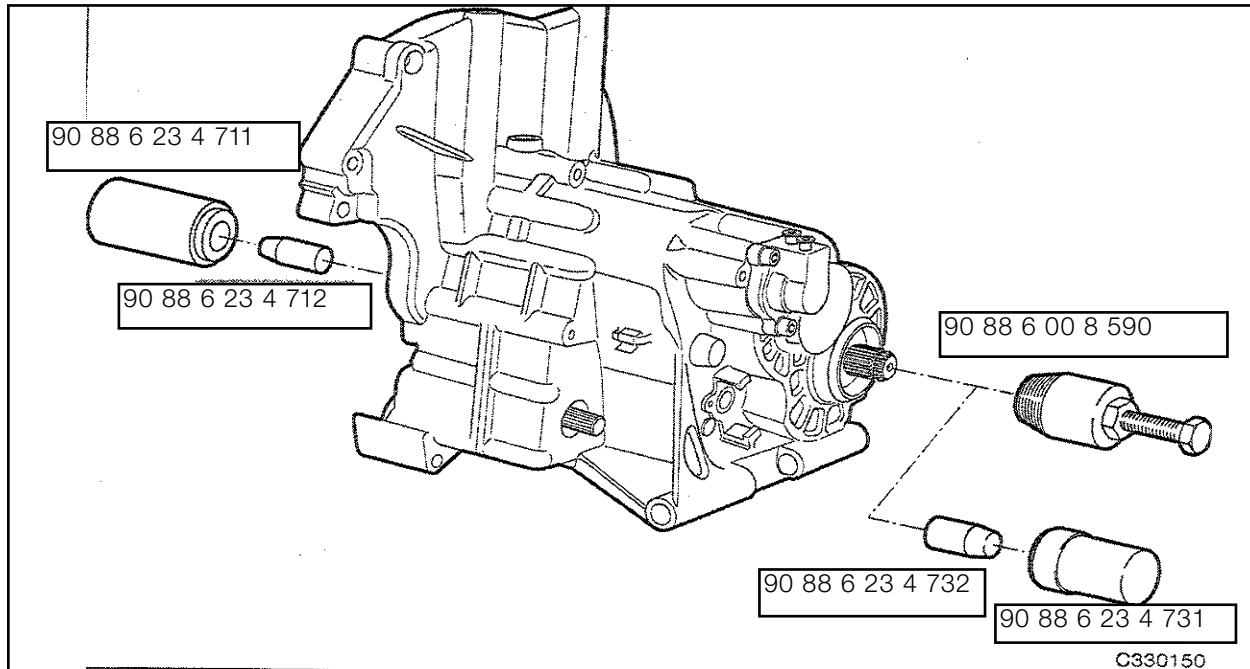

Note: All shaft sealing rings can be renewed with the gearbox installed, apart from the input side shaft sealing ring on the input shaft. If the gearbox is dismantled completely, all shaft sealing rings must be renewed. Before installing shaft sealing rings, oil their sealing lips lightly.

Renewing input shaft sealing ring at input side

- Lever the shaft sealing ring out with a screwdriver.
- Drive the new sealing ring in with the sealing lips facing inward, using slip-over sleeve, BMW No. 90 88 6 23 4 712, and drift, BMW No. 90 88 6 23 7 711.

Renewing output shaft sealing ring

Caution: Do not press the output shaft sealing ring out with a screwdriver, or the plastic disc behind it may be damaged.

- Screw puller, BMW No. 90 88 6 00 8 590, into shaft seal-ing ring and turn the hex bolt to remove the shaft sealing ring.
- Install the sealing ring with the sealing lips facing inward, using, BMW No. 90 88 6 23 4 732, and drift, BMW No. 90 88 6 23 4 731.

Renewing input shaft sealing ring at output side

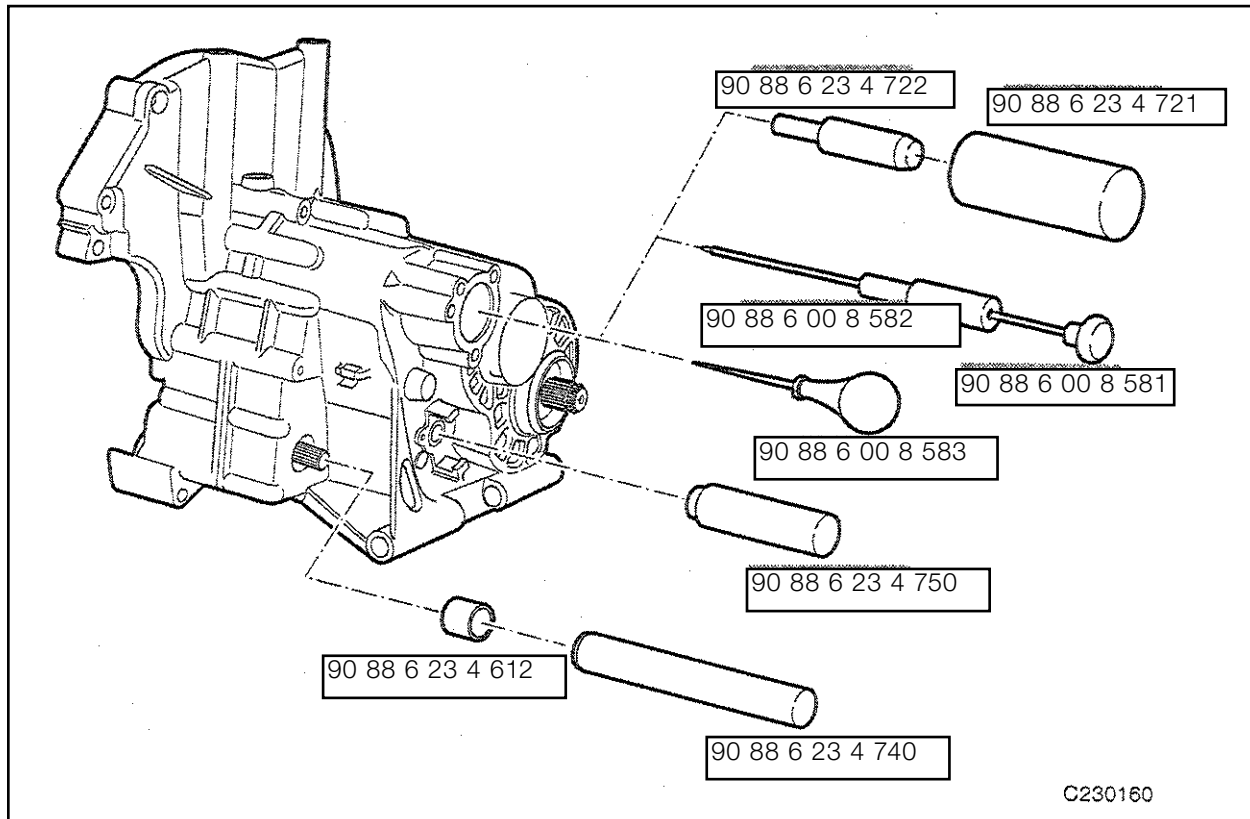

- Drill the shaft sealing ring with a 4 mm drill bit.
- Screw thrust rod, BMW No. 90 88 6 00 8 582, into cut out and remove the shaft sealing ring by slapping the weight rearward.
- Install the new sealing ring with the sealing lips facing inward, using slip-over sleeve, BMW No.90 88 6 23 4 722, and drift, BMW No. 90 88 6 23 4 721.

Renewing shaft sealing ring for selector drum

- Lever the shaft sealing ring out with a screwdriver.
- Install the new sealing ring with the sealing lips facing inward, using drift, BMW No. 90 88 6 23 4 750.

Renewing shaft sealing ring for selector shaft

- Lever the shaft sealing ring out with a screwdriver.
- Install the new sealing ring with the sealing lips facing inward, using slip-over sleeve, BMW No. 90 88 6 23 4 612, and drift, BMW No. 90 88 6 23 4 740.

Checking/adjusting fully compressed lengths of intermediate shaft

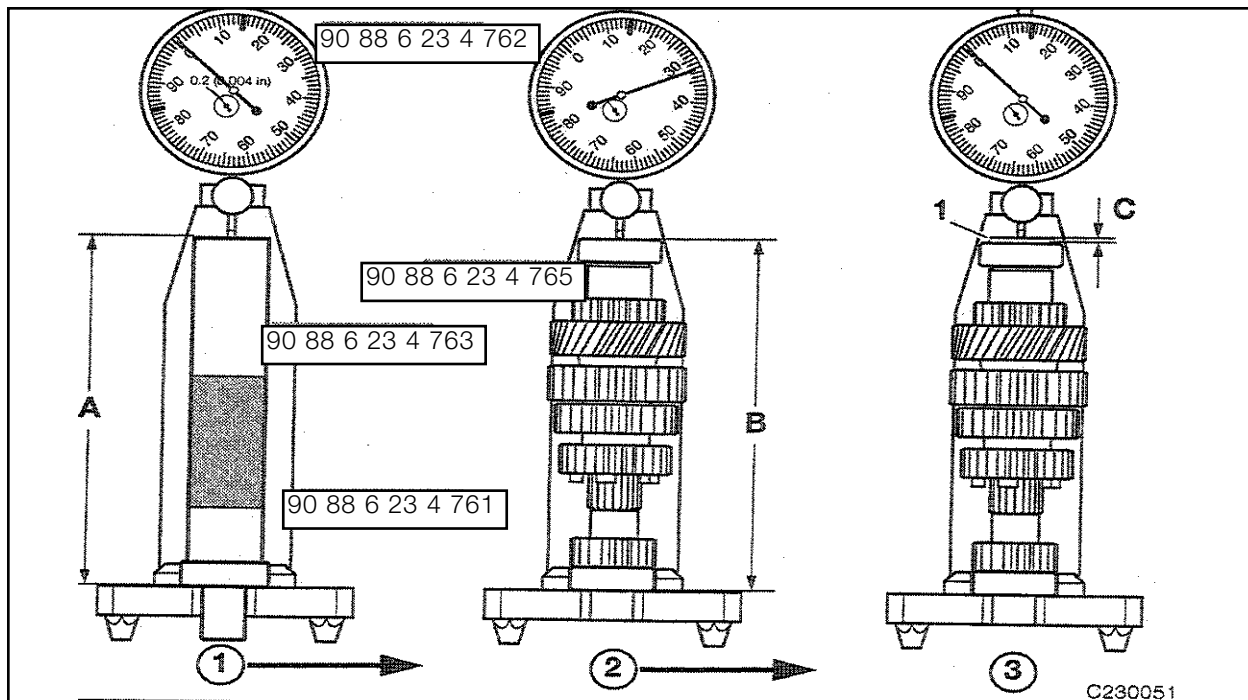

Caution: To adjust and check the fully compressed length, measure deviation from zero as described below and adjust with a shim washer. Before each measurement, even if the shaft is not, being installed, make sure that the deep-groove ball bearing is fully compressed.

- Pull off the input side deep-groove ball bearing with universal puller, BMW No. 88 88 6 00 7 500.

- Insert zero gauge, BMW No. 90 88 6 23 4 763, into measuring stand, BMW No. 23 4 761.
- Secure dial gauge, BMW No. 90 88 6 23 4 762, in rear mounting hole on measuring stand, BMW No. 90 88 6 23 4 761, and set to 0.2 mm (0.008 in) Maximum deviation preload.
- Using the dial gauge, zero to dimension "A" of the zero gauge, BMW No. 23 4 763.
- Remove the zero gauge from the measuring fixture.
- Place measuring disc, BMW No. 90 88 6 23 4 765, on the intermediate shaft.
- Place deep-groove ball bearing on measuring disc.
- insert intermediate shaft in measuring stand.
- Using dial gauge, measure deviation from zero of dimension "B" at inner bearing race. The deviation from zero is equivalent to the thickness "C" of spacing washer (1).

- Place a spacing washer (1) of the thickness just determined on the inner bearing race and check deviation from zero.

$$A = B + C$$

Caution: The maximum permitted deviation from zero must not be exceeded.

- Remove the intermediate shaft from the measuring fixture.
- Take off spacing washer, the deep-groove ball bearing and the measuring disc.
- Place a spacing washer (1) of the determined thickness on the intermediate shaft and press on the deep-groove ball bearing.

Adjusting dimensions for intermediate shaft: Maximin Deviation

| | |
|-------------------------------|---|
| from zero -0.05 mm (0.002 in) | to 0.00 mm |
| Fully compressed length | 198.95 to 199.00 mm (7,833 to 7,835 in) |

Checking/adjusting fully compressed length of output shaft

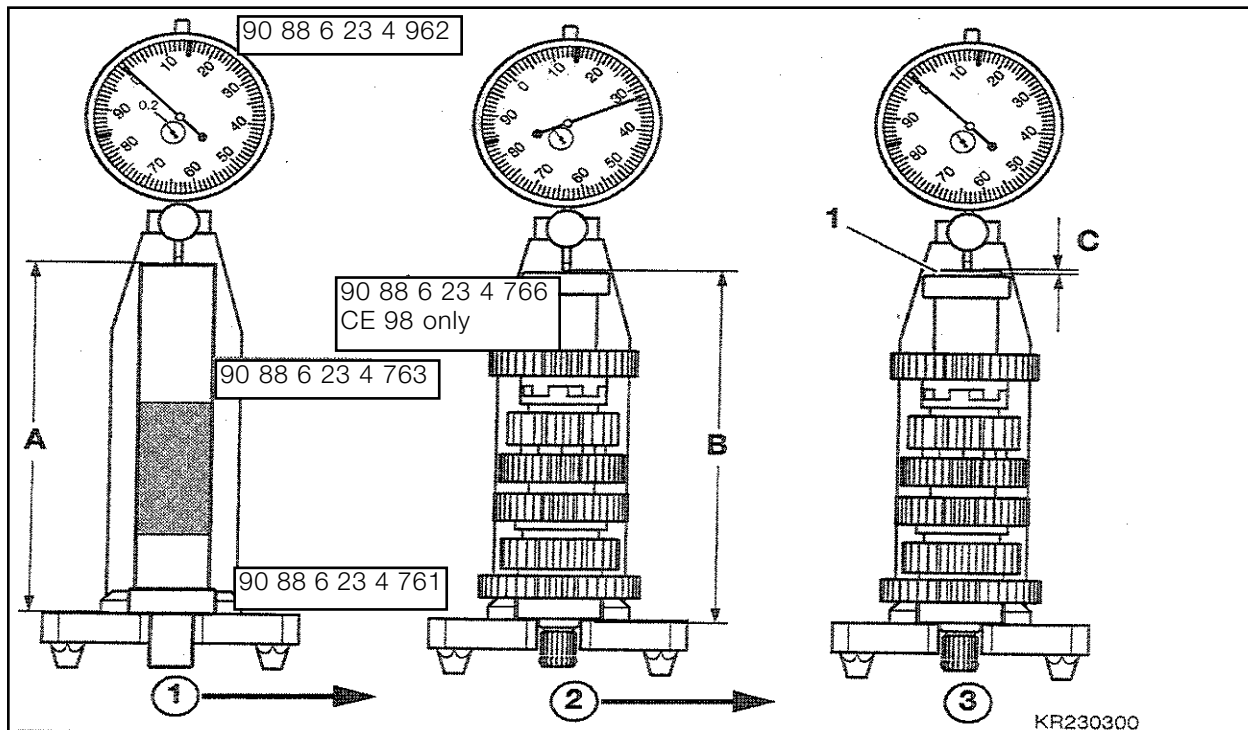

Caution: To check and adjust the fully-compressed length, measure deviation from zero as described below and adjust with a shim washer. Before each measuring step, even if the shaft is not to be installed, make sure that the deep-groove ball bearing is fully compressed.

- Pull off input side deep-groove ball bearing with universal puller, BMW No. 88 88 6 00 7 500.
- Insert zero gauge, BMW No. 90 88 6 23 4 763, in to measuring stand, BMW No. 90 88 6 23 4 761, Secure dial gauge, BMW No. 90 88 6 23 4 962, in rear mounting hole on measuring stand, BMW No. 90 88 6 23 4 761, and set to 0.2 mm (0,008 in) preload.
- Using the dial gauge, zero to dimension "A" of the zero gauge, BMW No. 90 88 6 23 4 763.
- Remove the zero gauge from the measuring fixture.
- Place the measuring disc, BMW No. 90 88 6 23 4 766, on the output shaft.
- Place the deep-groove ball bearing on the measuring disc.
- Insert the output shaft into the measuring stand.

Using the dial gauge, measure the deviation from zero of dimension "B" at the inner bearing race. The deviation from zero represents thickness "C" of spacing washer (1).

- Place spacing washer (1) of the thickness just determined on the inner bearing race, and check deviation from zero.

$$A = B + C$$

Caution: The maximum deviation from zero must not be exceeded.

- Remove output shaft from measuring fixture.
- Take off spacing washer, deep-groove ball bearing and measuring disc.
- Place a spacing washer (1) of the determined thickness on the output shaft and press on the deep-groove ball bearing.

Output shaft adjusting dimensions: Maximum deviation
 from zero .. -0.05 mm (0.002 in) to 0.00 mm/in
 Fully-compressed length, 192.95 to 193.00 mm (7.596, 7.598 in)

Checking/adjusting fully compressed length of input shaft

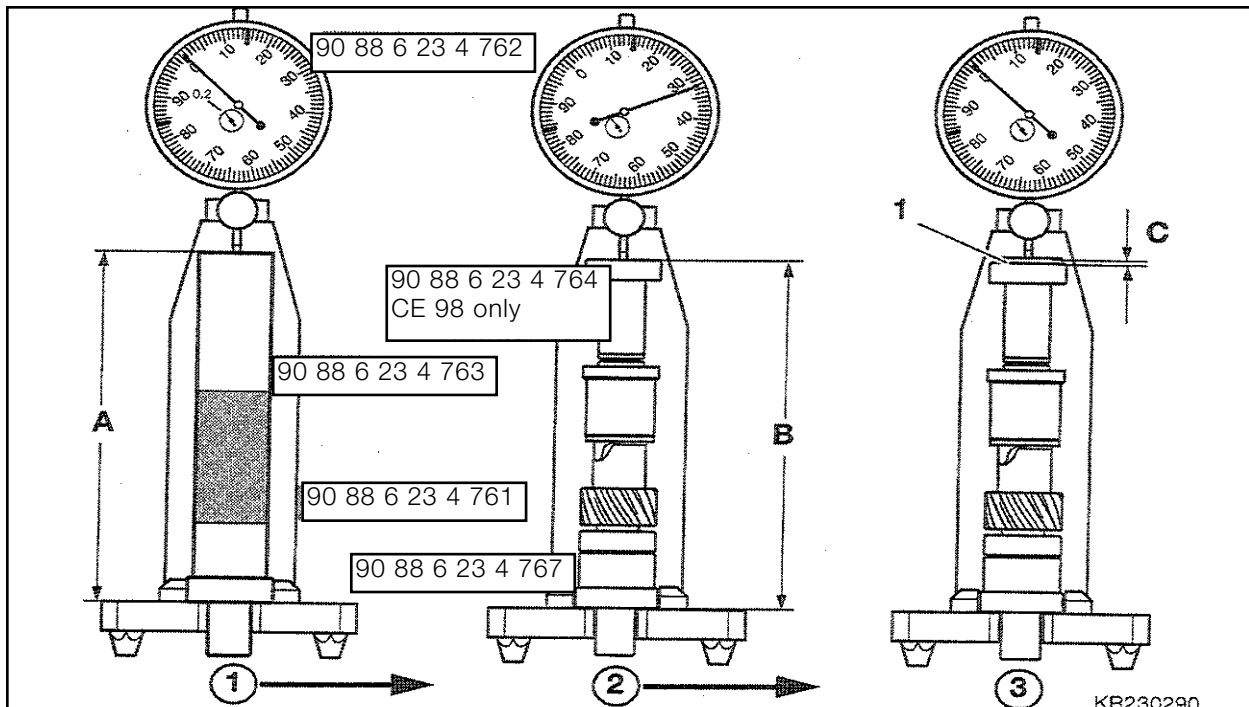

Caution: To adjust and check the fully compressed length, deviation from zero must be measured as described below, and adjusted by means of a shim washer. Make sure before each measuring step, even if the shaft is not being installed, that the deep-groove ball bearing is fully compressed.

- Pull off output side deep-groove ball bearing with universal puller, BMW No. 88 88 6 00 7 500.
- Insert zero gauge, BMW No. 90 88 6 23 4 763, into measuring stand, BMW No. 90 88 6 23 4 761.
- Secure dial gauge, BMW No. 90 88 6 23 4 762, in front, mounting hole on measuring stand, BMW No. 90 88 6 23 4 761, and set to 0.2 mm (0.008 in) preload.
- Using dial gauge, zero to dimension "A" of the zero gauge, BMW No. 90 88 6 23 4 763.
- Remove the zero gauge from the measuring fixture.
- Mount measuring disc, BMW No. 90 88 6 23 4 764, on the input shaft.
- Place the deep-groove ball bearing on the measuring disc.
- Insert input shaft with adapter disc, BMW No. 90 88 6 23 4 767, in measuring stand.
- Using the dial gauge, measure deviation from zero to dimension "B" at the inner bearing race. The deviation from zero represents the thickness "C" of spacing washer (1).
- Place a spacing washer (1) of the determined thickness on the inner bearing race and check the deviation from zero. $A = B + C$

Caution: The maximum deviation from zero must not be exceeded.

- Take the input shaft out of the measuring fixture
- Take off the adapter disc, spacing washer, deep-groove ball bearing and measuring disc.
- Place a spacing washer (1) of the determined thickness in position and press the deep-groove ball bearing an to the input shaft.

Adjusting dimensions for input shaft.

Maximum deviation

from zero -0.05 mm (0.002 in) to 0.00 mm/in

Fully compressed length 138.55 to 138.60 mm (5.455 to 5.457 in)

Checking/adjusting fully compressed length of selector drum

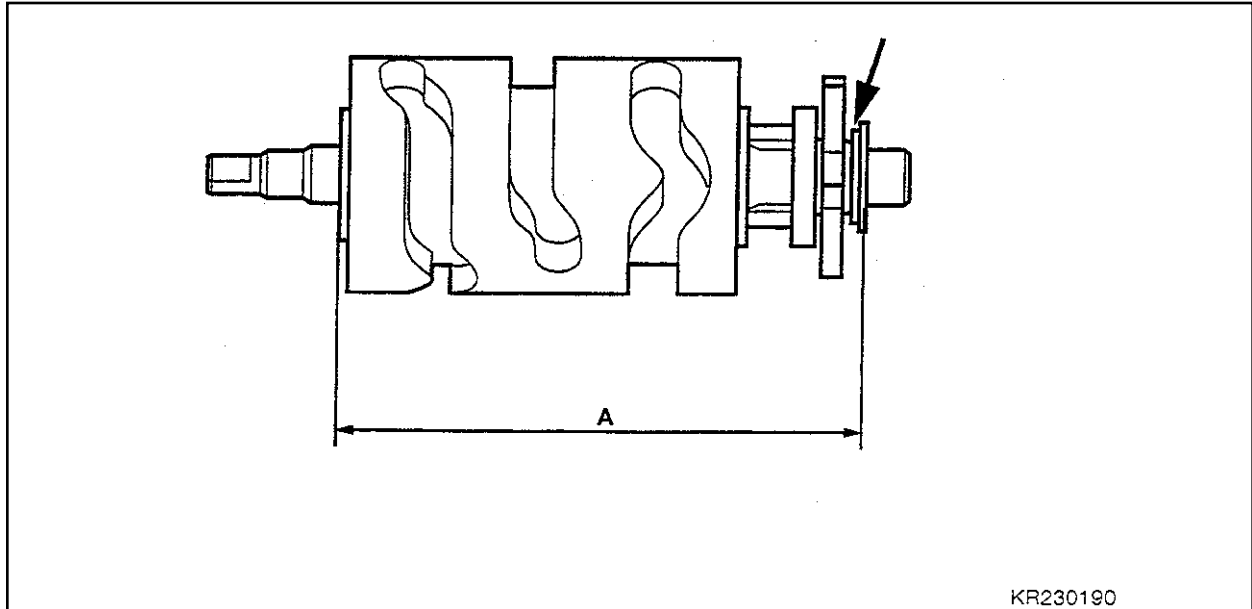

KR230190

- Place spacing washer and both thrust washer on the selector drum.
- Use depth gauge to determine fully compressed length "A".
- If necessary, adjust fully compressed length "A" with the shim washer (arrow).

Fully compressed lengths:

| | | | |
|--------------------|------------|------------------|-----------|
| Intermediate shaft | 198-95 | 199.00 mm (7.833 | 7.835 in) |
| Output shaft | 192.95 | 193.00 mm (7.596 | 7.598 in) |
| Input shaft ... | 138.55 ... | 138.60 mm (5.455 | 5.457 in) |
| Selector drum | 111.80 | 111.90 mm (4.402 | 4.406 in) |

Installing gearbox shafts

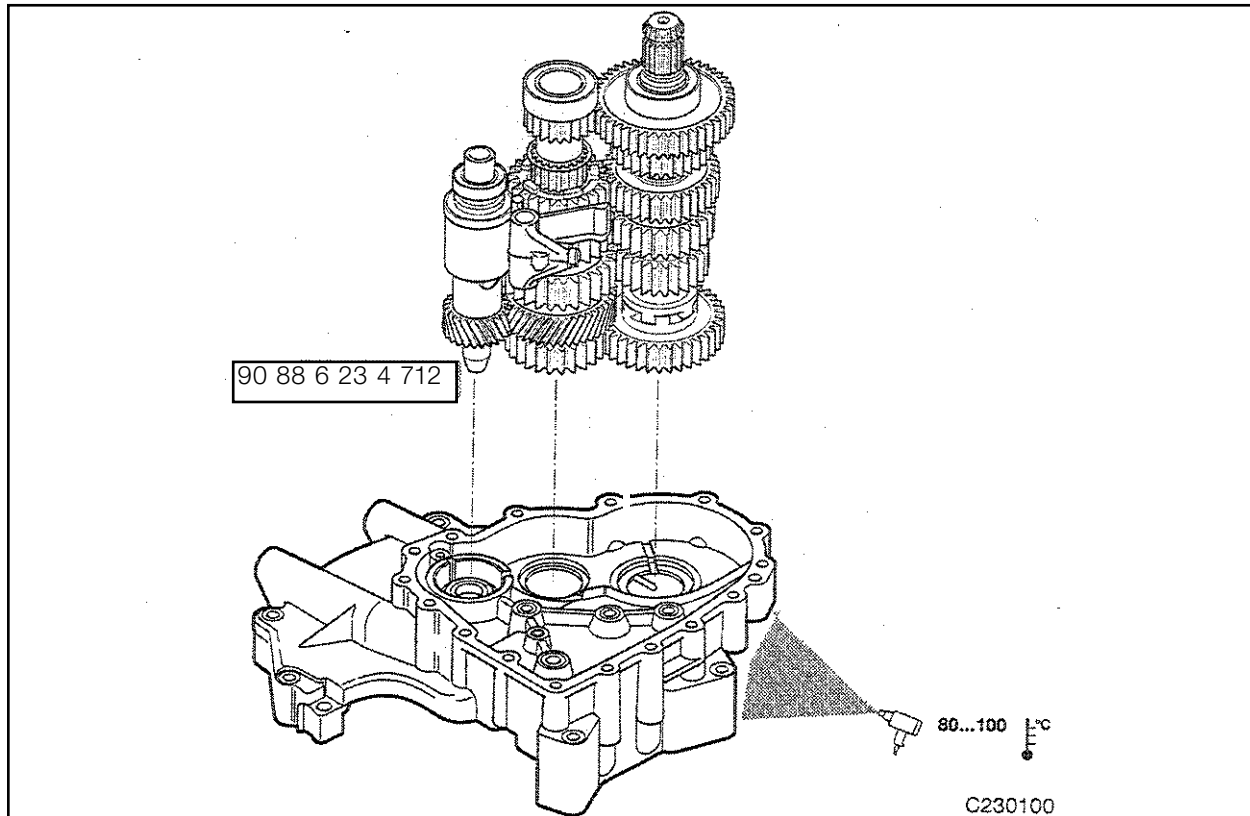

- Install input, output and intermediate shaft.

Caution: Before installing, the gearbox shafts, housing and cover must be thoroughly cleaned and examined for damage. All shaft sealing rings must be renewed.

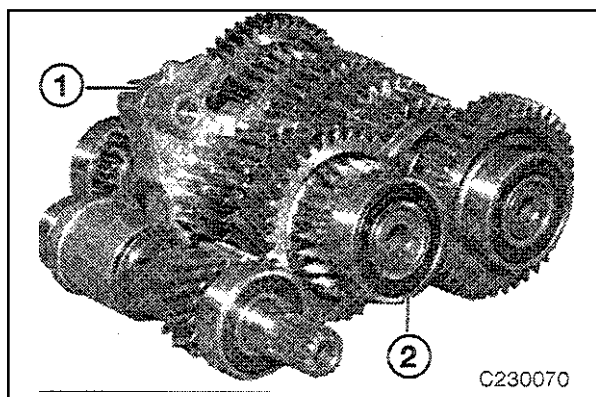

- Insert selector shaft (1) into intermediate shaft (2).

- Align input, output, and intermediate shafts so that their gear teeth mesh and the selector fork is in the position illustrated.
- Push slip over sleeve, BMW No. 90 88 6 234 712, onto the input shaft splines.

This is only necessary if the shaft sealing ring is installed.

- Heat the bearing points on the cover to 80 ... 100° C (176 ... 212° F).
- Insert the input, output and intermediate shafts together.

Caution: Check that the gearbox shafts are correctly seated.

- Install the 1 st/3rd gear and 2nd/4th gear selector forks.

Shimming selector shaft

Caution: The selector shaft does not have to be shimmed before installation unless the bearing bushing, the housing or the complete selector shaft were renewed.

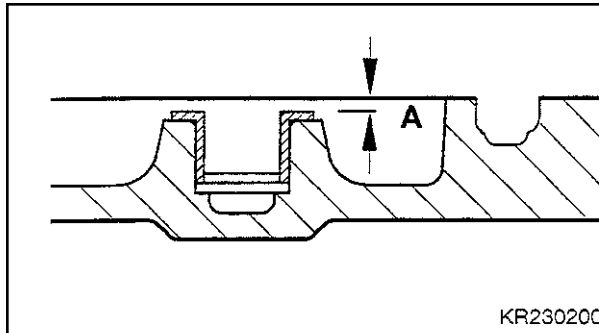

- Measure distance "A" from the shouldered bushing to the cover joint face.

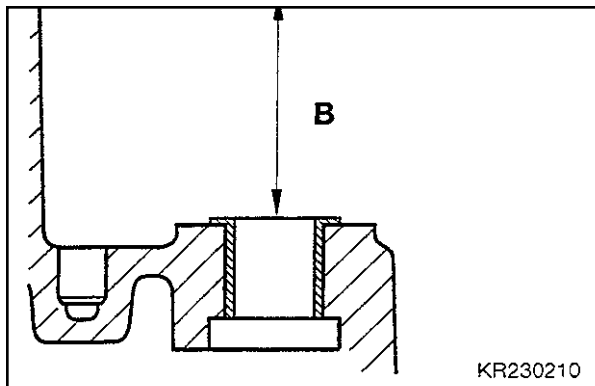

- Measure distance "B" from the shoulder bushing to the housing joint face.

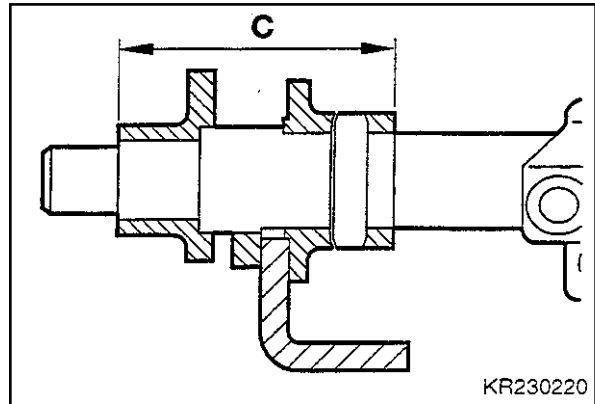

- Measure distance "C" from the shoulder on the selector shaft to the back of the sleeve.
- Determine end play as follows:

Distance "A" + distance "B" = Distance "D"
 Distance "D" - distance "C" = distance "E"
 Distance "E" - thickness of spacing washer = end play.

Installing selector shaft

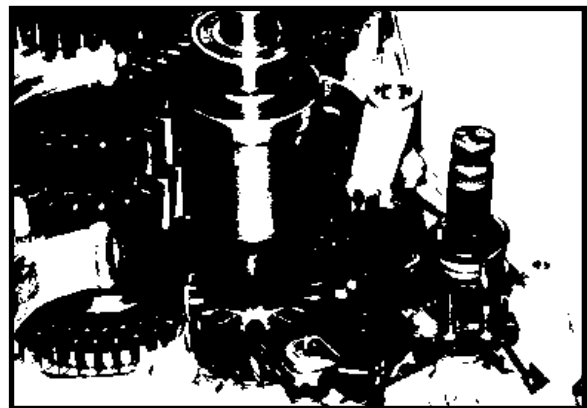

- Place a spacing washer of the determined thickness in position and install selector shaft (26).
- Measure distance "B" from the shouldered bush.
- Engage torsion spring (28) in positioning to the housing joint face.

End play:

Selector shaft in housing
 0.1 - 0.3 mm (0.004 - 0.012 in)

Installing selector drum

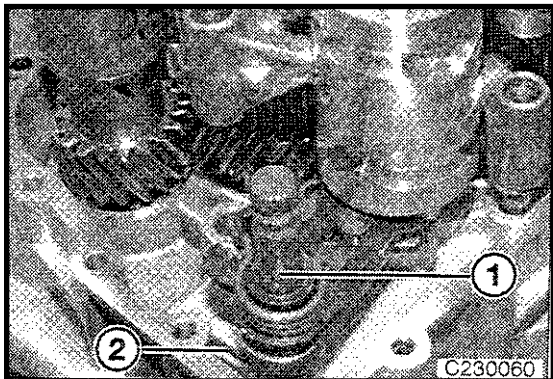
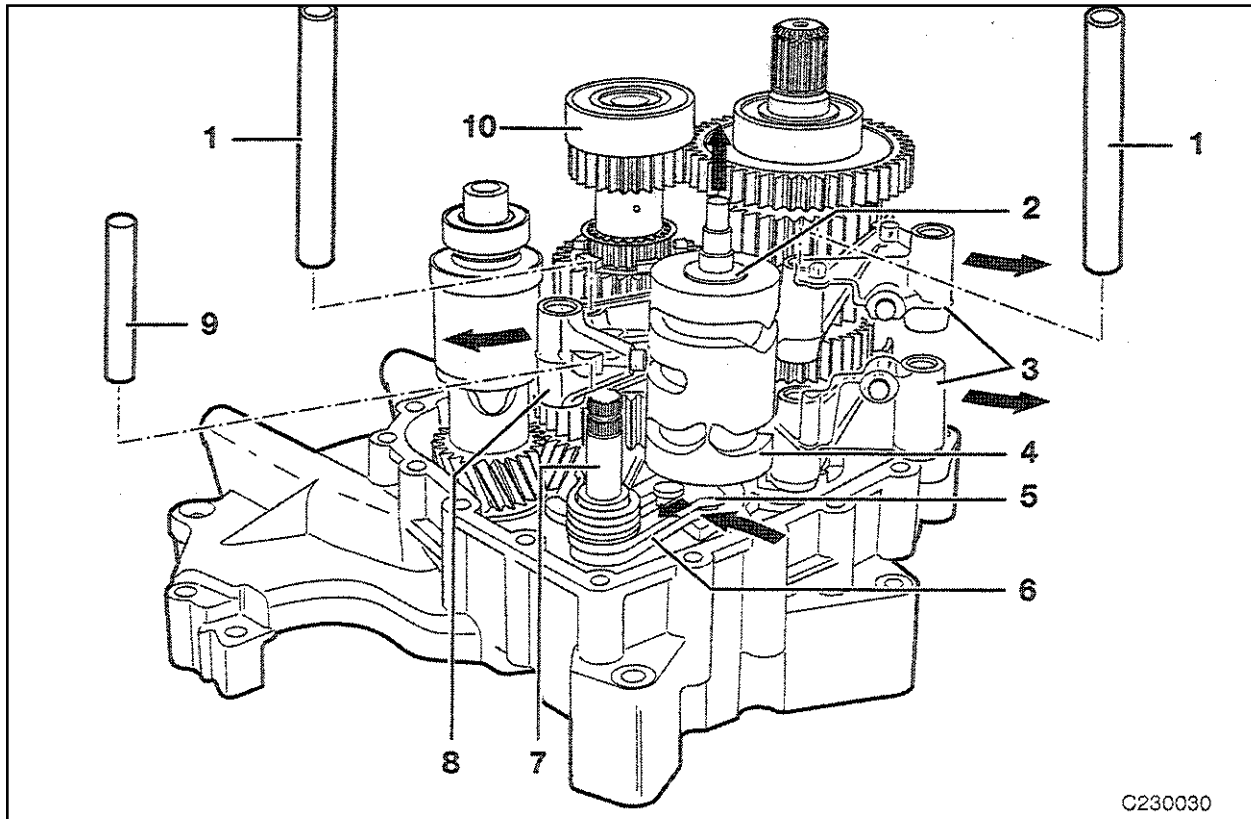

Installing selector shaft

- Place a spacing washer of the determined thickness in position and install selector shaft (1).
- Engage torsion spring (2) in the housing.

Installing selector drum

- Place a spacing washer of the determined thickness and the input side thrust washer on selector drum (6) and secure with a small amount of grease.
- Swing locking lever (8) out towards the edge of the cover and install the selector drum.
- Swing locking lever (8) towards selector drum (6) and engage it in position together with guide plate (7).
- Place shift forks (5, 10) in the guide tracks.
- Install selector shafts (3).
- Install locking pin (11).
- Place thrust washer (4) on the selector drum.

Installing gearbox housing

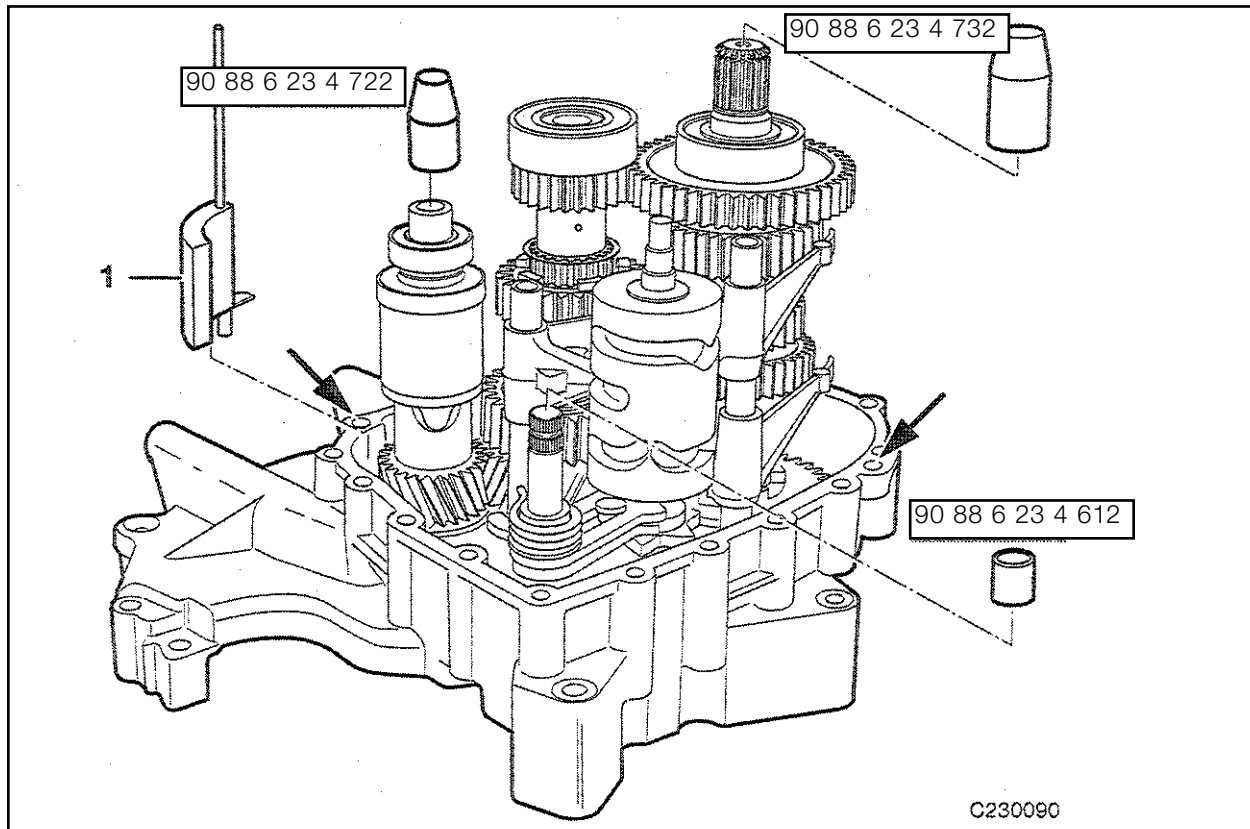

- Install locating pins (arrows) in correct position in cover.

Caution: The sealing faces must be free from oil or grease. The sealing material sets within 30 minutes; within this time, place the housing in position and screw it down.

- Apply Loctite 5203 sealing material to the cover joint face with a gun.
- Place slip over sleeve, BMW No. 90 88 6 23 4 732, on the output shaft.
- Place slip over sleeve, BMW No. 90 88 6 23 4 712, on the input shaft.
- Place slip over sleeve, BMW No. 90 88 6 23 4 612, on the selector shaft.

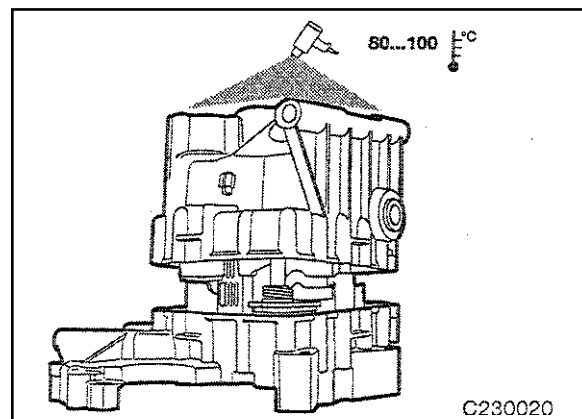

- Heat the bearing seats in the housing to 80 ... 100°C and place the housing on the cover.

ompleting the gearbox

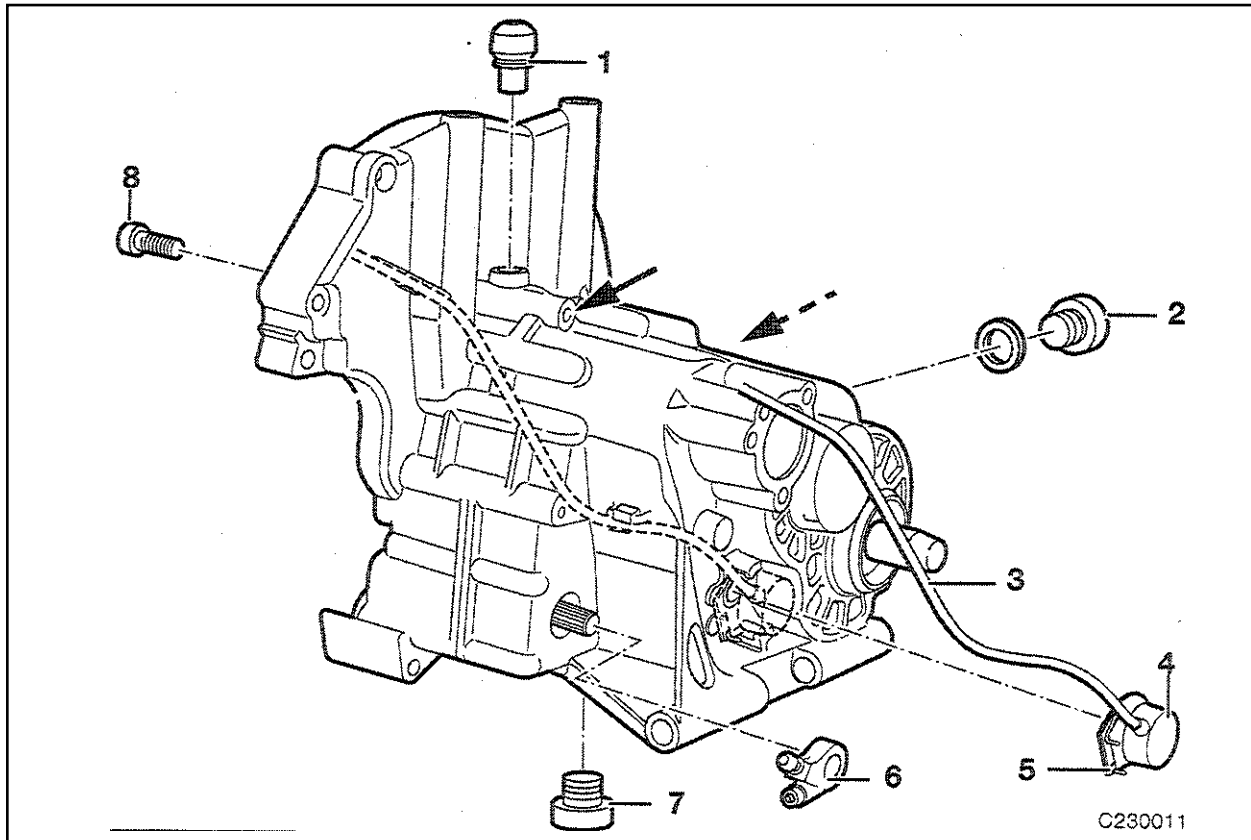

- Insert screws (8) and tighten in a crosswise pattern.
- Install neutral indicator (4) and clip wire (3) into position.
- Install breather (1).
- Clean metal particles off the magnet in drain plug (7).
- Insert oil drain plug (7).
- Insert oil filler and level check plug (2) with a new sealing ring.

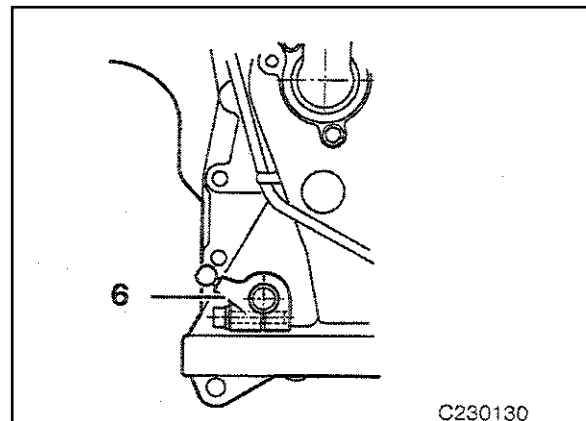

- Install shift lever (6) in the correct position.

Note: In the correct position the mark on the selector lever (dot) is aligned with the mark on the selector shaft (line).

After assembling the gearbox, perform a functional check.

Installing the gearbox

Install the gearbox in reverse order of disassembly.

Tightening torques:

| | |
|----------------------------------|-------|
| Cover to housing | 09 Nm |
| Oil drain Plug | 55 Nm |
| Oil filler/level check plug | 23 Nm |
| Selector lever to Selector shaft | 09 Nm |
| Gearbox to intermediate flange | 22 Nm |
| Starter motor to gearbox | 20 Nm |

Disclaimer

This training reference book is not intended to be a complete and all inclusive source of servicing , repairing or troubleshooting the motorcycle. This is only part of the training information designed to assure that uniform procedures and information are presented to all participants at the BMW Motorcycle Training Center.

The technician must always refer to and adhere to the following official BMW AG and BMW NA service publications.

- Training Materials
- Repair Manuals
- Service Information Bulletins
- MoDiTeC

Service Information Bulletins are issued by the BMW Motorcycle Service Department, regarding changes in operation, and repair or maintenance procedures.

The information contained in this training course material is solely intended for class room participants in this training course conducted by the BMW Motorcycle Training Staff.

Information Status, (indicated on front cover).

For changes/additions to the technical data, please refer to current information issued by the BMW NA Motorcycle Service Department.

R 1200 C Gearbox Tools

| | | |
|------------------|------------------|------------------------|
| 90 88 6 00 1 520 | 90 88 6 23 4 711 | 90 88 6 23 4 761 |
| 90 88 6 00 1 581 | 90 88 6 23 4 712 | 90 88 6 23 4 762 |
| 88 88 6 00 2 510 | 90 88 6 23 4 721 | 90 88 6 23 4 763 |
| 88 88 6 00 7 500 | 90 88 6 23 4 722 | 90 88 6 23 4 784 |
| 90 88 6 00 8 582 | 90 88 6 23 4 731 | 90 88 6 23 4 765 CE 98 |
| 90 88 6 00 8 583 | 90 88 6 23 4 732 | 90 88 6 23 4 766 CE 98 |
| 90 88 6 00 8 590 | 90 88 6 23 4 740 | 90 88 6 23 4 767 |
| 90 88 6 23 4 612 | 90 88 6 23 4 750 | |

d:\

Work Shop Operating Materials

Most chemicals are no longer inventoried by BMW NA, however most are available from vendors. Only one source has been listed here, however most of the chemicals listed have more than one supplier. For a more complete list of chemicals please review SI #2731 in Main Group #3.

| Item | Use | NLA Number |
|---------------------------------------|---|-----------------|
| Lubricant | | |
| Optimoly MP 3 | High performance lubricating paste | 07 55 9 062 476 |
| Optimoly TA | High temperature assembly paste | 18 21 9 062 599 |
| Silicone grease 300, heavy | Damping grease | 07 58 9 058 193 |
| Retinax A | Taper roller bearing grease | 81 22 9 407 710 |
| Contact spray | Contact spray | 81 22 9 400 208 |
| Sealant | | |
| 3-Bond 1209 | Surface sealant | 07 58 9 062 376 |
| Loctite 574 | Surface sealant | 81 22 9 407 301 |
| Curil K | Heat-conductive sealant | 81 22 9 400 243 |
| 2 Hylomar SO 32 M | Permanently elastic sealant | 81 22 9 400 339 |
| Adhesives and retaining agents | | |
| Loctite 648 | Structural adhesive, ultra high speed | 07 58 9 067 732 |
| Loctite 638 | Joint connector | 07 58 9 056 030 |
| Loctite 243 | Thread retainer, medium strength | 07 58 9 056 031 |
| Loctite 270 | Thread retainer, strong | 81 22 9 400 086 |
| Loctite 2701 | Thread retainer | 33 17 2 331 095 |
| Loctite 454 | Cyanacrylate_adhesive | 07 58 9 062 157 |
| 3 Bond 1110 B | Joint adhesive | 07 58 9 056 998 |
| Cleaner | | |
| Brake cleaner | Brake cleaner | 81 22 9 407 704 |
| Testing agent | | |
| Penetrant MR 68 | Crack testing agent for aluminum housings | 81 22 9 407 494 |

Loctite technical hot line 1 800 321-9188

| Use | New source | Order number |
|--------------------|------------|-----------------|
| BMW Lube #10 | (BMW) | 07 55 1 467 614 |
| Never-seize | (Loctite) | 80078/(PX 133K) |
| Same | (BMW) | 07 58 9 058 193 |
| BMW Lube #10 | (BMW) | 07 55 1 467 614 |
| Contact cleaner | (Loctite) | 80068/(PX 109D) |
| Sealing compound | (Loctite) | 80036/(PX 66BR) |
| Loctite 574 | (Loctite) | 51813 |
| Permatex 3D | (Loctite) | Permatex 3D |
| Hylomar SQ 32 M | (BMW) | 81 22 9 400 339 |
| Loctite 648 | (Loctite) | 21443 |
| Loctite 638 (grn) | (Loctite) | 64000 |
| Loctite 243 (blue) | (Loctite) | 24200 or 24300 |
| Loctite 270 | (Loctite) | 27100 |
| Loctite 270 | (Loctite) | 27100 |
| Loctite 454 | (Loctite) | 69400 |
| Adhesive 1110B | (Loctite) | 49450 |
| Brake cleaner | (Loctite) | 82585 |
| Penetrator | (Loctite) | 80052/80068 |

